



Catalog No. H-CRYO100  
Jan. 2020

# Cryogenic Service Valves



## **Cryogenic Needle Valves**

1/2 in. to 1 in. Class 150, 300

## **Cryogenic Top Entry Wedge-Seat Ball Valves**

1/2 in. to 1 in. Class 150, 300, 600, 900

## **Cryogenic Top Entry Trunnion Ball Valves**

2 in. to 12 in. Class 150

**HY-LOK CORPORATION**

© 2003, 2007, 2014, 2020 HY-LOK CORPORATION All rights reserved



**FOR A BETTER**



All Your Solution Provider “HY-LOK”



**TOMORROW**

## Introduction

With long experience, Hy-Lok provides world-class engineered valve products and services to onshore, offshore plants across the globe. We provide leadership in design, manufacture and technical services for cryogenic service valves, using reliability data from our unique performance evaluation systems.

We deliver world-class quality which translates into optimum reliability and performance for plant operators globally. Hy-Lok holds world-class engineering intelligence at its core. This ethos is set to drive exciting new valve innovations to meet the evolving needs of the industry.

## Standards

- The valve is designed in accordance with API 6D
- The body is designed and manufactured in accordance with ASME B16.34
- Flange dimensions in accordance with ASME B16.5
- Welding ends in accordance with ASME B16.25
- Fire Tested to API 607

## Key Features

- Self relieving for prevent over pressure in the body cavity and extension bonnet.
- The flow arrow are marked on the body according to the pressure relief.
- Extends valve packing and operator away from cryogenic fluid.
- Allows operation in normal working temperature range.
- Top entry for in-line maintenance.
- Easy in line maintenance.

## Functional Test

- Gas Leak Rates are Bubble Tight Shutoff \ API 598 \ API 6D \ ISO 5208
- Cryogenic Service Leak Rates comply with standards such as BS 6364

## Nondestructive Test

- Casting and other pressure containing parts :
  - 10 % Radiographic tests per ASME B16.34
  - 100% Penetrant tests per ASME B16.34
- Butt welded ends :
  - 100% Radiographic tests per ASME B16.34



Cryogenic  
Needle Valve



Cryogenic Top Entry  
Wedge-Seat Ball Valve



Cryogenic Top Entry  
Trunnion Ball Valve

## Cryogenic Testing

### Test Sequence

- 1) Ambient Temperature
  - Shell Leakage Test
  - Seat Leakage Test
- 2) Cryogenic Temperature
  - Initial Proving Test
  - Open/Close 20 Operating Cycles Test
  - Torque Test
  - Seat Leakage Test at Incremental Pressures
  - Shell Leakage Test
- 3) Ambient Temperature
  - Shell Leakage Test
  - Seat Leakage Test



## Fire Safety Testing

### Test Sequence

- 1) During Burn Period (30min. / 750°C~1000°C)
  - Through Seat Leakage
- 2) During Burn and Cool Down Period (5min. / Max. 100°C)
  - External Leakage
- 3) After Cool Down
  - Through Seat Leakage Test
- 4) After Operation
  - External Leakage Test

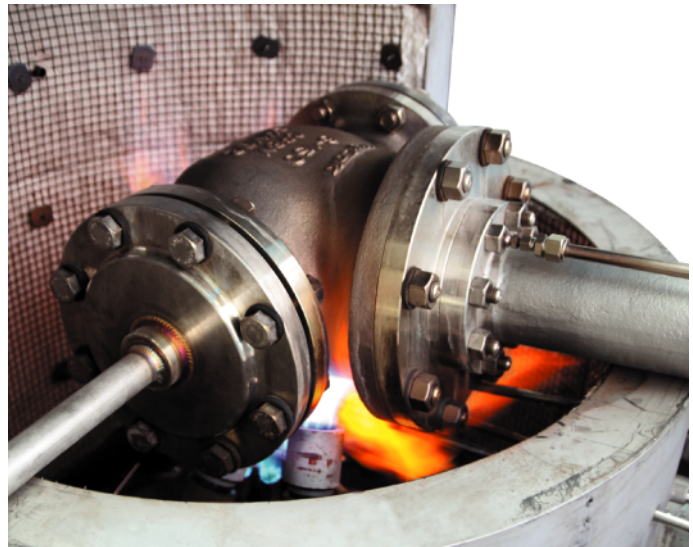

## Type Approval Certificates

Valve Type	Size	Pressure Rating	Class
Cryogenic Needle Valve	1/2 in. & 1 in.	CL.150	ABS, BV, LR, DNV GL, KR
Cryogenic Needle Valve	1/2 in.	CL. 300	KR
Cryogenic Needle Valve	1/2 in. & 1 in.	CL. 150 to 1500	BV
Cryogenic Wedge-Seat Valve	1/2 to 2 in.	CL. 150/300/600 & 900	BV
Cryogenic Top Entry Trunnion Valves	2 to 12 in.	CL. 150	BV



## Cryogenic Needle Valves

### Bolted Extension Bonnet - Stainless Steel 1/2 in. to 1 in. & Class 150, 300

Hy-Lok's Cryogenic Needle Valves have been designed to eliminate leakages, maximize lifetime operation and reduce maintenance and spares cost. Prevents over pressure if liquid trapped in the extension bonnet.

#### Features & Benefits

- Bonnet flange design allows easy maintenance, even in confined spaces.
- Revolving disc ensures non-rotating seat contact for an extended leak free life.
- Minimize clearance between extension bonnet I.D and stem O.D.
- Prevent liquid trapped in the extension bonnet (Bi-directional).
- Non-welded bonnet extension.
- Spring loaded packing is long life.
- Dust cap with Position indicator.
- Stainless steel hand wheel.



#### Specifications

##### Pressure Rating :

- ASME Class 150, 300

##### End Connection

- Flanged End
- Screwed End
- Butt Weld End

##### Materials

- ASTM A182 F316/F316L Stainless Steel
- ASTM A351 CF8M/CF3M Stainless Steel

#### Material of Construction

Component	Material Specification
1 Top Entry Body	ASTM A182 F316/316L or A351 CF8M/3M
2 Revolving Disc	316 Stainless Steel
3 Bonnet Gasket	Graphite & 316 SS
4 Bonnet Flange	ASTM A182 F316 or A351 CF8M
5 Bonnet Bolt	ASTM A320 B8M. Grad 2
6 Extension Bonnet	316 Stainless Steel
7 Extension Stem	316 Stainless Steel
8 Stem Packing	Graphite
9 Position Indicator	316 Stainless Steel
10 Handle Wheel	ASTM A351 CF8M

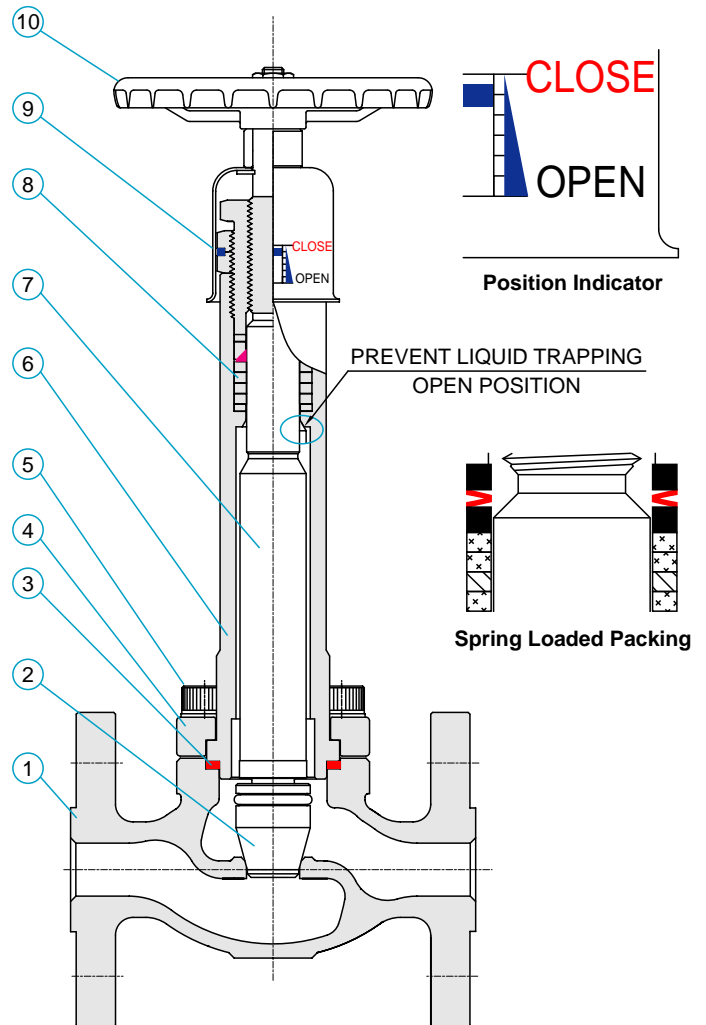

## Cryogenic Needle Valves

### Flange Ends

1/2 in. to 1 in. & Class 150, 300

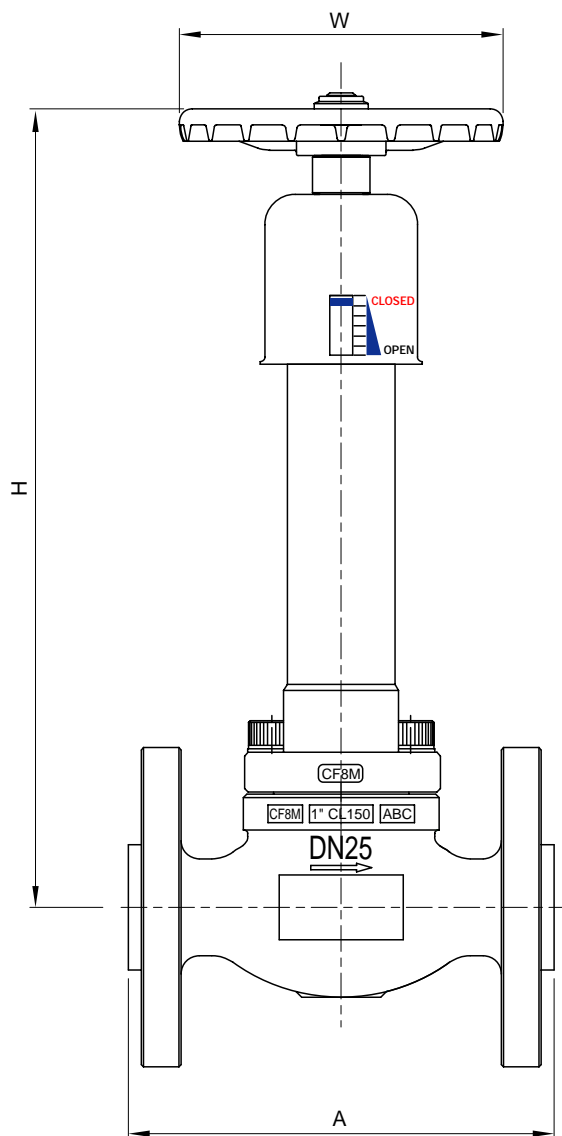

Part No.	End Connection			Dimensions (mm)			
	Size	Rating	End	A	H	W	Weight(Kg)
VCRYONC - 8FA	1/2 in.	#150	RF	114	230	90	2.9
VCRYONC - 8FB	1/2 in.	#300	RF	114	230	90	2.9
VCRYONC - 16FA	1 in.	#150	RF	140	260	100	5.4
VCRYONC - 16FB	1 in.	#300	RF	140	260	100	5.4

## Cryogenic Needle Valves

Butt-weld to Flange Ends

1/2 in. to 1 in. & Class 150, 300

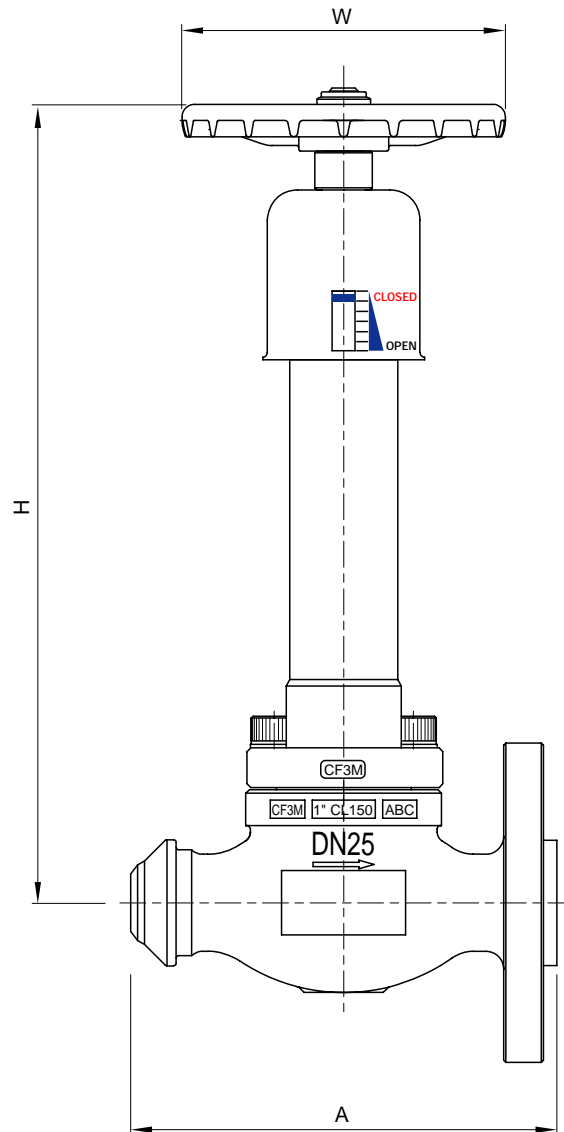

Part No.	End Connection			Dimensions (mm)			
	Size	Rating	End	A	H	W	Weight(Kg)
VCRYONC- 8BWFA	1/2 in.	#150	BW x RF	114	230	90	2.6
VCRYONC- 8BWFB	1/2 in.	#300	BW x RF	114	230	90	2.6
VCRYONC-16BWFA	1 in.	#150	BW x RF	140	260	100	4.6
VCRYONC-16BWFB	1 in.	#300	BW x RF	140	260	100	4.6

## Cryogenic Needle Valves

### Butt-weld Ends

1/2 in. to 1 in. & Class 150, 300

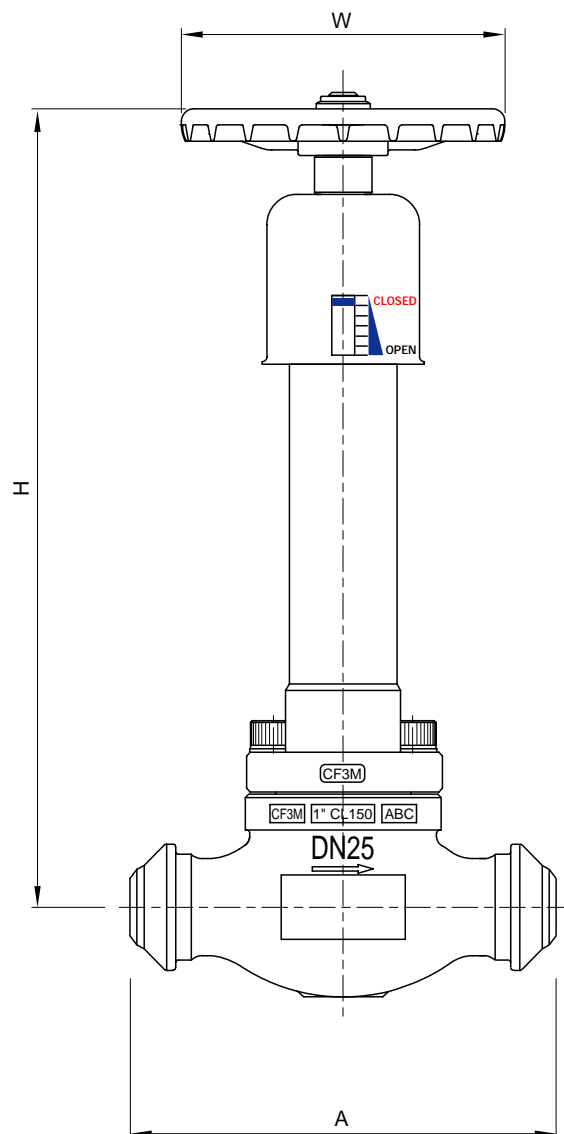

Part No.	End Connection			Dimensions (mm)			
	Size	Rating	End	A	H	W	Weight(Kg)
VCRYONC- 8BWA	1/2 in.	#150	BW	114	230	90	2.2
VCRYONC- 8BWB	1/2 in.	#300	BW	114	230	90	2.2
VCRYONC-16BWA	1 in.	#150	BW	140	260	100	3.7
VCRYONC-16BWB	1 in.	#300	BW	140	260	100	3.7



## Cryogenic Needle Valves

### Flange to Screwed Ends

1/2 in. to 1 in. & Class 150, 300

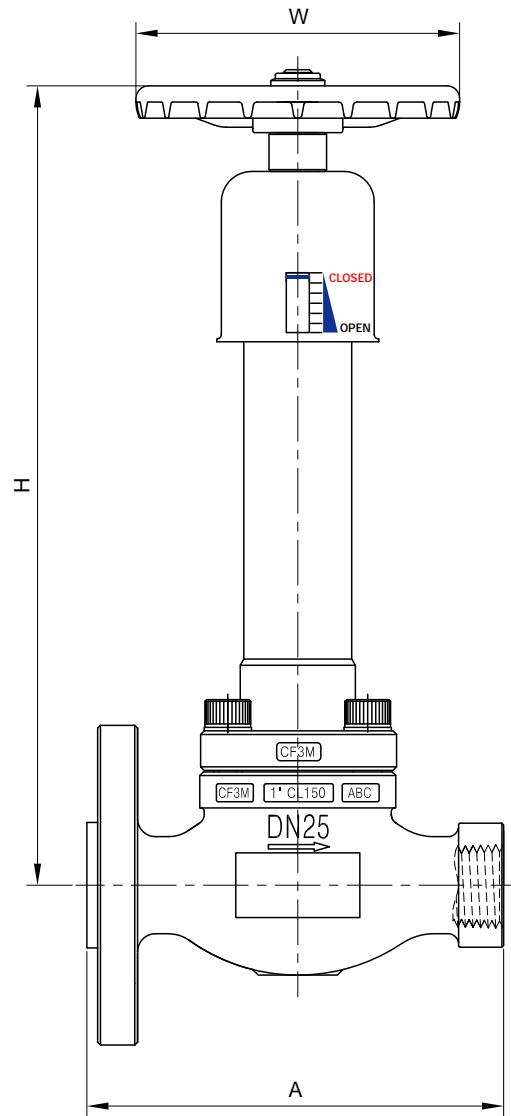

Part No.	End Connection			Dimensions (mm)			
	Size	Rating	End	A	H	W	Weight(Kg)
VCRYONC- 8FNA	1/2 in.	#150	RF x NPT	114	230	90	2.6
VCRYONC- 8FNB	1/2 in.	#300	RF x NPT	114	230	90	2.6
VCRYONC-16FNA	1 in.	#150	RF x NPT	140	260	100	4.6
VCRYONC-16FNB	1 in.	#300	RF x NPT	140	260	100	4.6

## Cryogenic Needle Valves

### Screwed Ends

1/2 in. to 1 in. & Class 150, 300

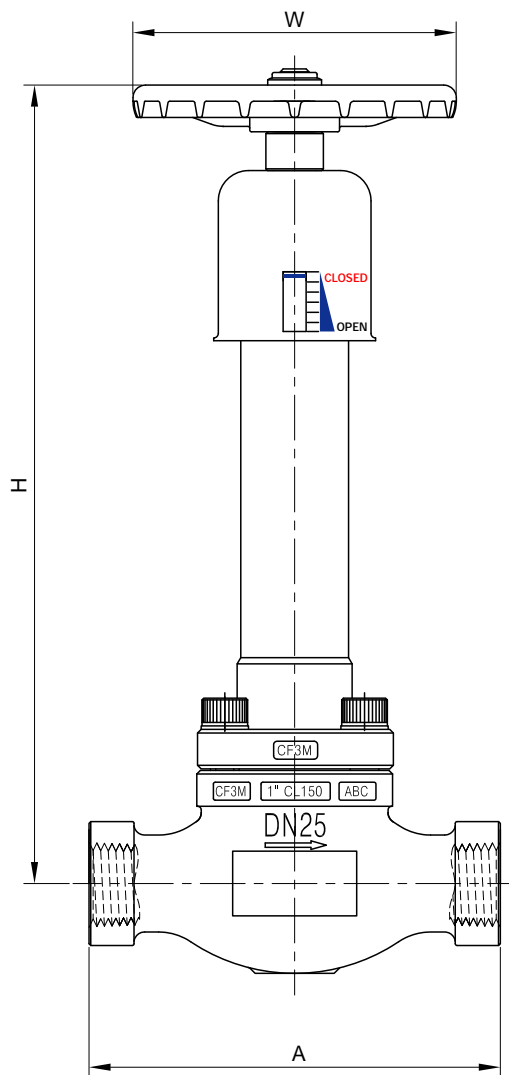

Part No.	End Connection			Dimensions (mm)			
	Size	Rating	End	A	H	W	Weight(Kg)
VCRYONC- 8NA	1/2 in.	#150	NPT	114	230	90	2.2
VCRYONC- 8NB	1/2 in.	#300	NPT	114	230	90	2.2
VCRYONC-16NA	1 in.	#150	NPT	140	260	100	3.7
VCRYONC-16NB	1 in.	#300	NPT	140	260	100	3.7

## Cryogenic Needle Valves

Butt-weld to Flange Ends(Angle Path)

1/2 in. to 1 in. & Class 150, 300

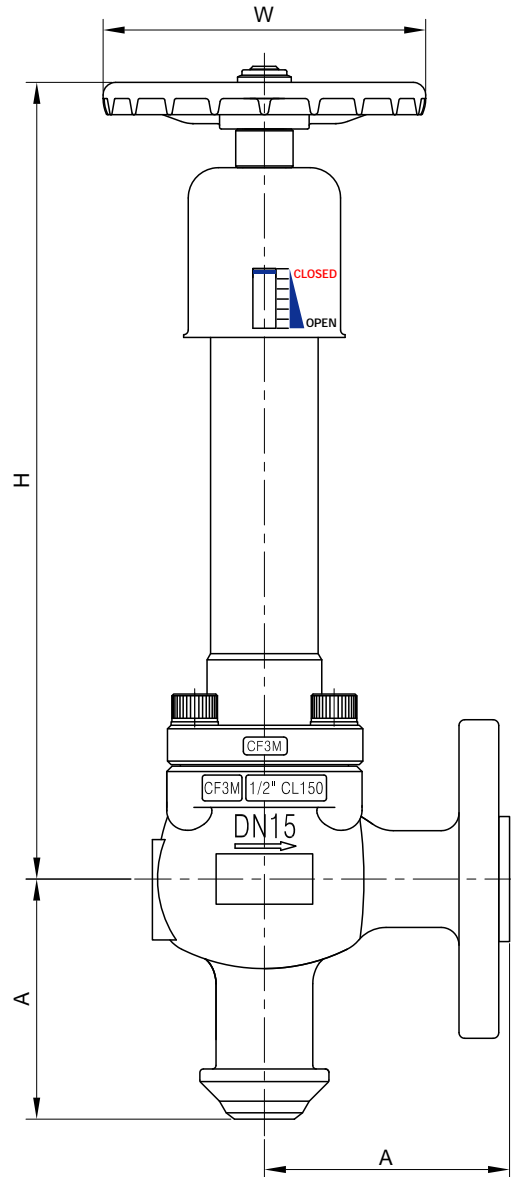

Part No.	End Connection			Dimensions (mm)			
	Size	Rating	End	A	H	W	Weight(Kg)
VCRYONA- 8BWFA	1/2 in.	#150	BW x RF	114	230	90	2.6
VCRYONA- 8BWFB	1/2 in.	#300	BW x RF	114	230	90	2.6
VCRYONA-16BWFA	1 in.	#150	BW x RF	140	260	100	4.6
VCRYONA-16BWFB	1 in.	#300	BW x RF	140	260	100	4.6

## Cryogenic Needle Valves

Butt-weld to Screwed Ends(Angle Path)

1/2 in. to 1 in. & Class 150, 300

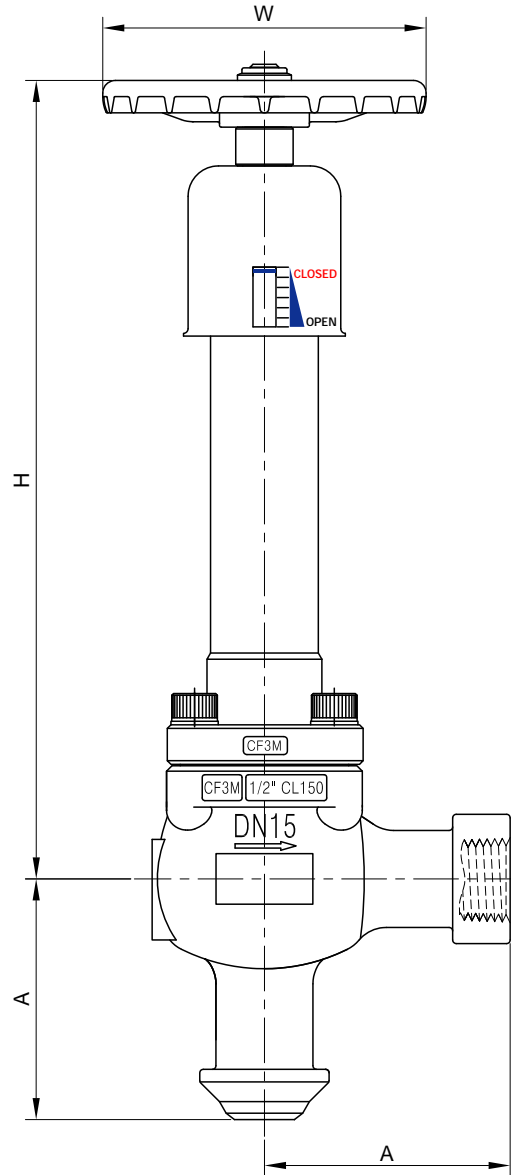

Part No.	End Connection			Dimensions (mm)			
	Size	Rating	End	A	H	W	Weight(Kg)
VCRYONA- 8BWNA	1/2 in.	#150	BW x NPT	114	230	90	2.6
VCRYONA- 8BWNB	1/2 in.	#300	BW x NPT	114	230	90	2.6
VCRYONA-16BWNA	1 in.	#150	BW x NPT	140	260	100	4.6
VCRYONA-16BWNB	1 in.	#300	BW x NPT	140	260	100	4.6

## Cryogenic Top Entry Wedge-Seat Ball Valves

### Extended Bonnet - Stainless Steel

1/2 in. to 1 in. & Class 150, 300, 600, 900

Hy-Lok's Cryogenic Top Entry Wedge-Seat Ball Valves have been designed to in-line for maintenance, which provides a remarkable time and cost savings for maintenance.

There is a pressure relief hole in the up-stream for prevent over pressure in the body cavity and extension bonnet.



### Features & Benefits

Upstream cavity pressure relief in the close position.

- Pressure relief through upstream side.
- Bi-directional.

Minimize clearance between extension bonnet I.D and stem O.D.

Non-welded bonnet extension.

Spring loaded packing is long life.

Top entry wedge-seat design.

Top entry for in-line maintenance.

Easy in line maintenance.

Anti static design.

Stainless steel lever handle.

### Specifications

#### Pressure Rating :

- ASME Class 150, 300, 900

#### End Connection

- Flanged End
- Screwed End
- Butt Weld End

#### Materials

- ASTM A351 CF8M/CF3M Stainless Steel

### Material of Construction

Component	Material Specification
1 Top Entry Body	ASTM A351 CF8M/CF3M
2 Wedge-Seat	PCTFE & Graphite
3 Bonnet Gasket	Graphite & 316 SS
4 Trunnion Ball	316 Stainless Steel
5 Bonnet Bolt	ASTM A320 B8M. Grad 2
6 Extension Bonnet	ASTM A351 CF8M
7 Extension Stem	316 Stainless Steel
8 Stem Packing	Graphite
9 Locking Device	316 Stainless Steel
10 Lever Handle	316 Stainless Steel

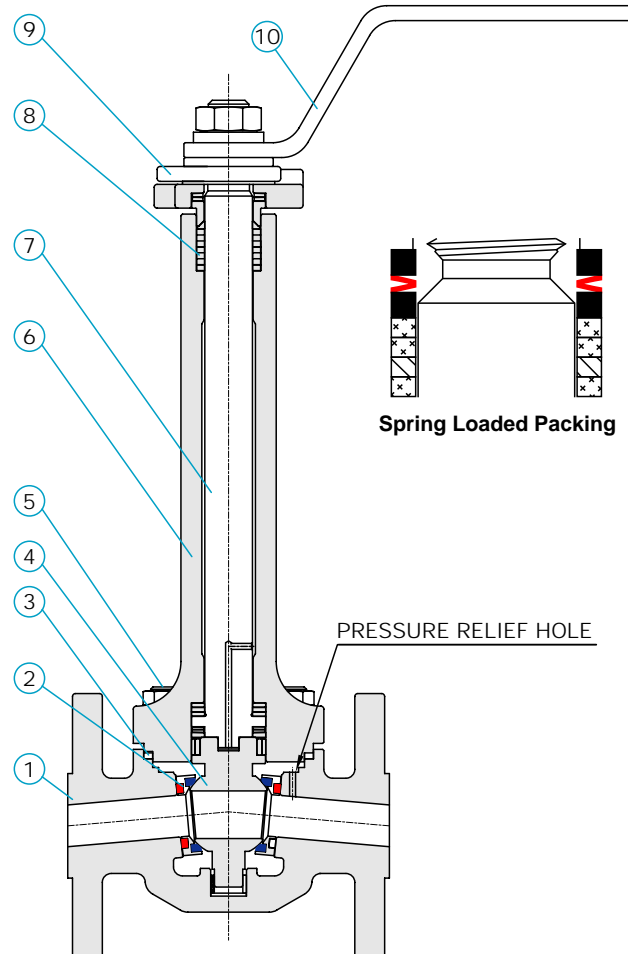

## Cryogenic Top Entry Wedge-Seat Ball Valves

### Flange Ends

1/2 in. to 1 in. & Class 150, 300, 600, 900

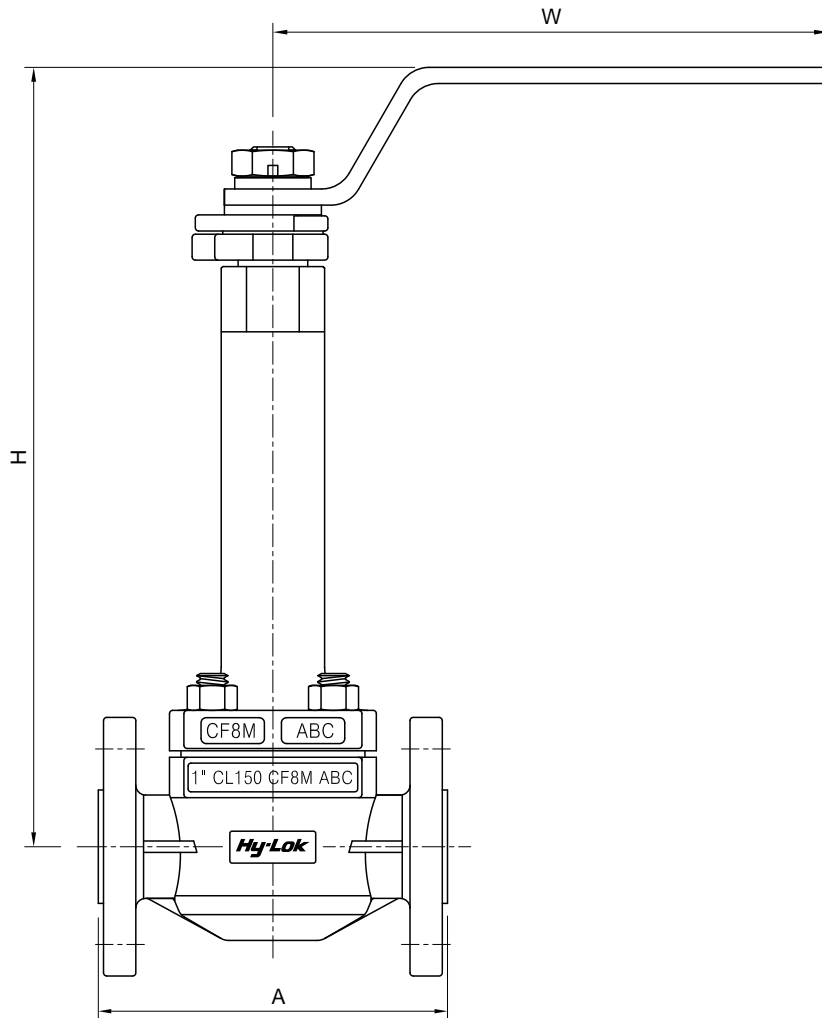

Part No.	End Connection			Dimensions (mm)			
	Size	Rating	End	A	H	W	Weight(Kg)
VCBOW- 8FA	1/2 in.	#150	RF	108	275	210	4.1
VCBOW- 8FB	1/2 in.	#300	RF	140	290	210	5.9
VCBOW- 8FC	1/2 in.	#600	RF	165	295	210	8.2
VCBOW- 8FD	1/2 in.	#900	RF	216	300	230	10.6
VCBOW-16FA	1 in.	#150	RF	127	290	230	6.0
VCBOW-16FB	1 in.	#300	RF	165	300	230	7.2
VCBOW-16FC	1 in.	#600	RF	216	300	230	13.7
VCBOW-16FD	1 in.	#900	RF	254	305	260	15.8



## Cryogenic Top Entry Wedge-Seat Ball Valves

Butt-weld to Flange Ends

1/2 in. to 1 in. & Class 150, 300, 600, 900

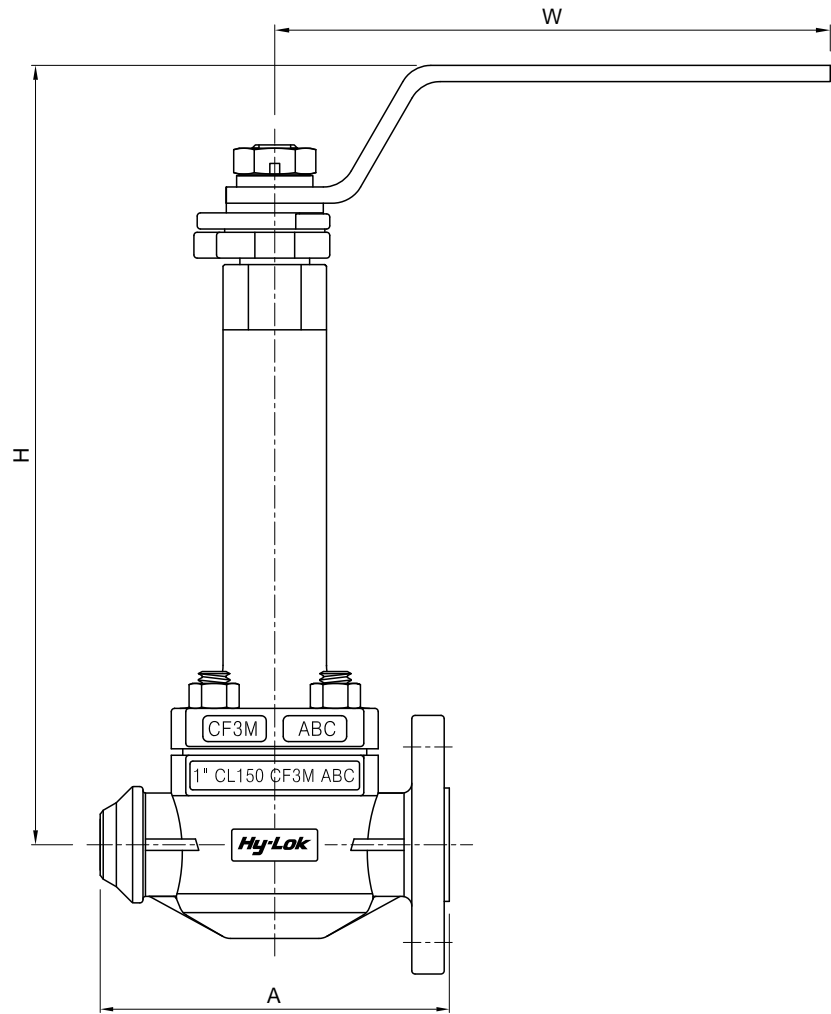

Part No.	End Connection			Dimensions (mm)			
	Size	Rating	End	A	H	W	Weight(Kg)
VCBOW- 8BWFA	1/2 in.	#150	BW x RF	108	275	210	3.8
VCBOW- 8BWFB	1/2 in.	#300	BW x RF	140	290	210	5.6
VCBOW- 8BWFC	1/2 in.	#600	BW x RF	165	295	210	7.5
VCBOW- 8BWFD	1/2 in.	#900	BW x RF	216	300	230	9.0
VCBOW-16BWFA	1 in.	#150	BW x RF	127	290	230	5.2
VCBOW-16BWFB	1 in.	#300	BW x RF	165	300	230	6.5
VCBOW-16BWFC	1 in.	#600	BW x RF	216	300	230	11.9
VCBOW-16BWFD	1 in.	#900	BW x RF	254	305	260	13.7

## Cryogenic Top Entry Wedge-Seat Ball Valves

**Butt-weld Ends**

1/2 in. to 1 in. & Class 150, 300, 600, 900

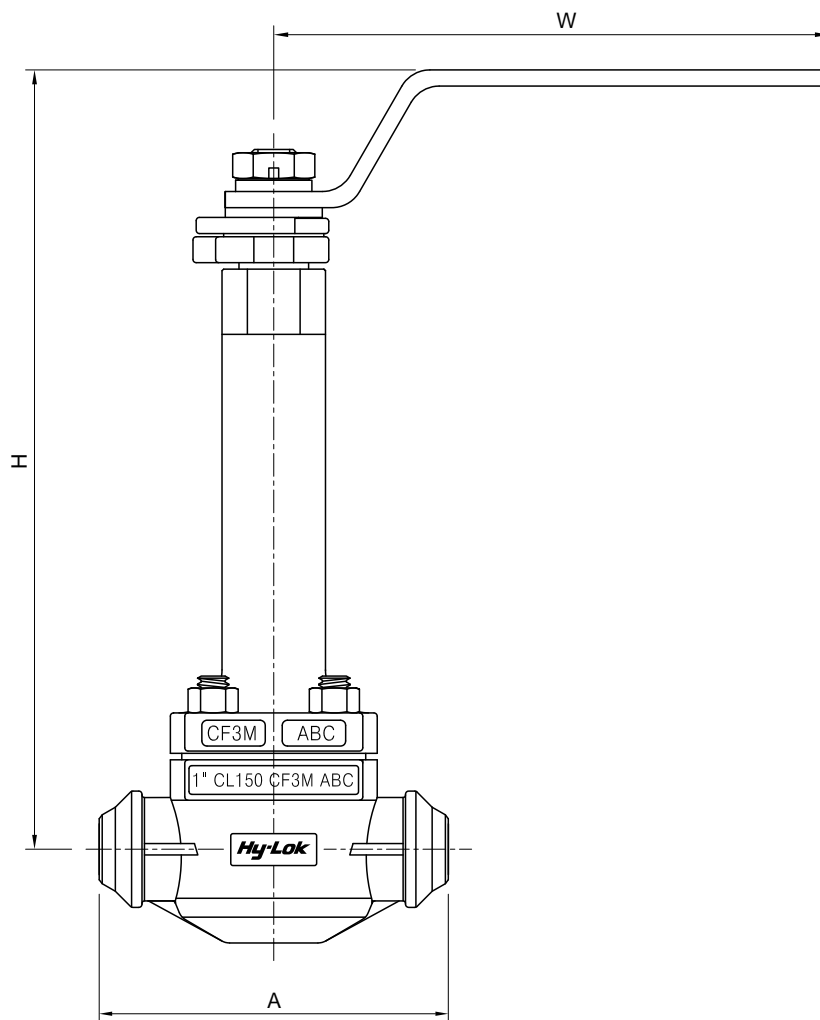

Part No.	End Connection			Dimensions (mm)			
	Size	Rating	End	A	H	W	Weight(Kg)
VCBOW- 8BWA	1/2 in.	#150	BW	108	275	210	3.5
VCBOW- 8BWB	1/2 in.	#300	BW	140	290	210	5.3
VCBOW- 8BWC	1/2 in.	#600	BW	165	295	210	6.8
VCBOW- 8BWD	1/2 in.	#900	BW	216	300	230	7.4
VCBOW-16BWA	1 in.	#150	BW	127	290	230	4.3
VCBOW-16BWB	1 in.	#300	BW	165	300	230	5.8
VCBOW-16BWC	1 in.	#600	BW	216	300	230	10.1
VCBOW-16BWD	1 in.	#900	BW	254	305	260	11.6

## Cryogenic Top Entry Wedge-Seat Ball Valves

### Flange to Screwed Ends

1/2 in. to 1 in. & Class 150, 300, 600, 900

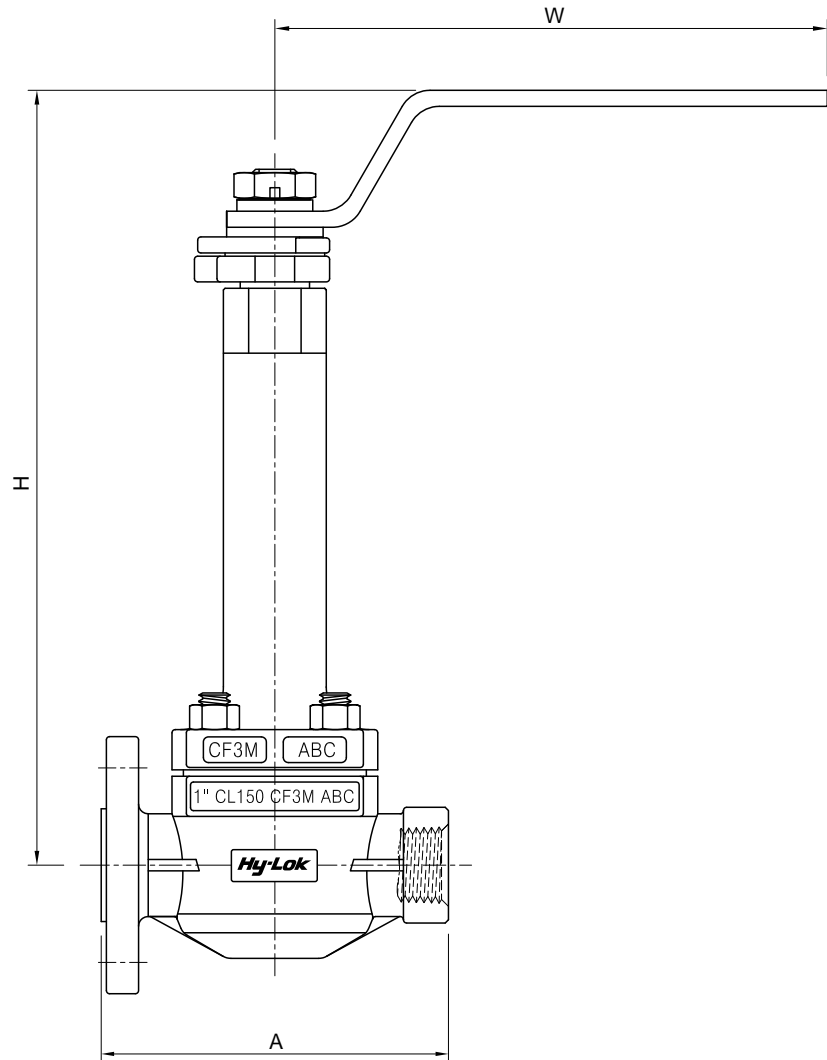

Part No.	End Connection			Dimensions (mm)			
	Size	Rating	End	A	H	W	Weight(Kg)
VCBOW- 8FNA	1/2 in.	#150	RF x NPT	108	275	210	3.8
VCBOW- 8FNB	1/2 in.	#300	RF x NPT	140	290	210	5.6
VCBOW- 8FNC	1/2 in.	#600	RF x NPT	165	295	210	7.5
VCBOW- 8FND	1/2 in.	#900	RF x NPT	216	300	230	9.0
VCBOW-16FNA	1 in.	#150	RF x NPT	127	290	230	5.2
VCBOW-16FNB	1 in.	#300	RF x NPT	165	300	230	6.5
VCBOW-16FNC	1 in.	#600	RF x NPT	216	300	230	11.9
VCBOW-16FND	1 in.	#900	RF x NPT	254	305	260	13.7

## Cryogenic Top Entry Wedge-Seat Ball Valves

### Screwed Ends

1/2 in. to 1 in. & Class 150, 300, 600, 900

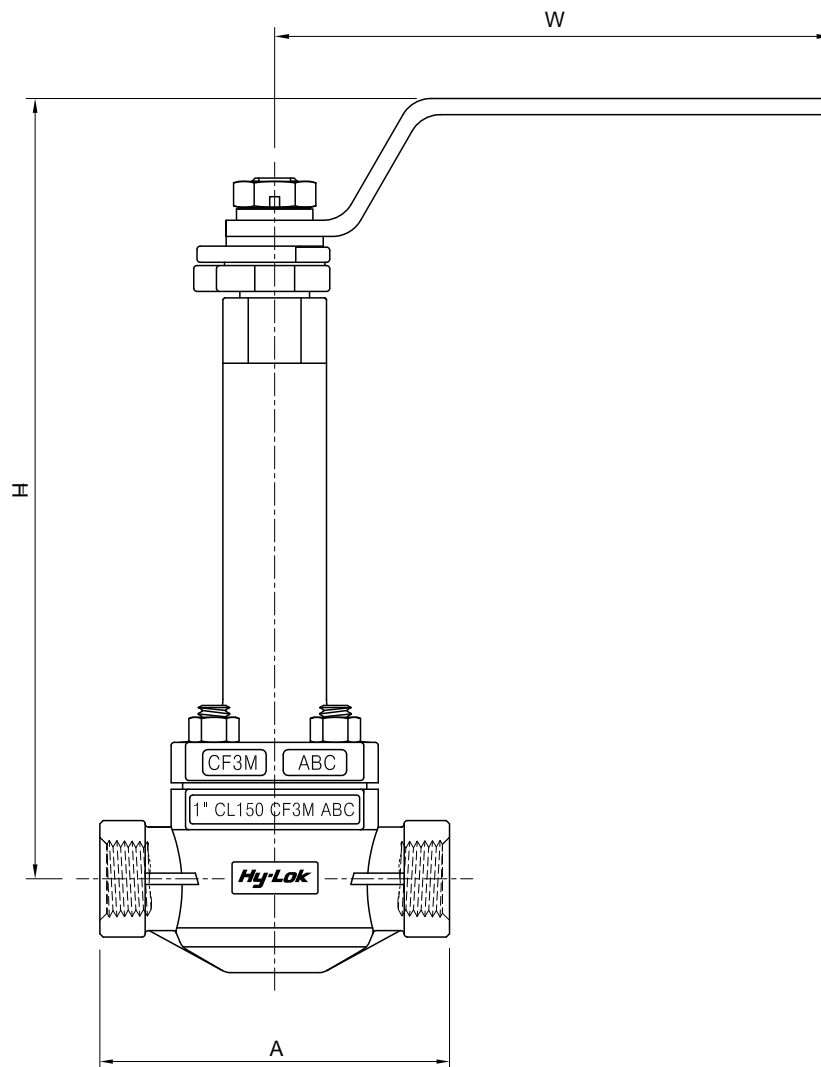

Part No.	End Connection			Dimensions (mm)			
	Size	Rating	End	A	H	W	Weight(Kg)
VCBOW- 8NA	1/2 in.	#150	NPT	108	275	210	3.5
VCBOW- 8NB	1/2 in.	#300	NPT	140	290	210	5.3
VCBOW- 8NC	1/2 in.	#600	NPT	165	295	210	6.8
VCBOW- 8ND	1/2 in.	#900	NPT	216	300	230	7.4
VCBOW-16NA	1 in.	#150	NPT	127	290	230	4.3
VCBOW-16NB	1 in.	#300	NPT	165	300	230	5.8
VCBOW-16NC	1 in.	#600	NPT	216	300	230	10.1
VCBOW-16ND	1 in.	#900	NPT	254	305	260	11.6

## Cryogenic Top Entry Trunnion Ball Valves

### Bolted Extension Bonnet - Stainless Steel 2 in. to 12 in. & Class 150

Hy-Lok's Cryogenic Top Entry Trunnion Ball Valves have been designed for in-line maintenance, which provides ease of operation at cryogenic service.

#### Features & Benefits

- 1-Single Piston Effect(SPE) and 1-Double Piston Effect(DPE) seat design.
  - Self relief through upstream side.
  - Bi-directional.
- Secondary seat sealing design.
- Non-welded bonnet extension.
- Top entry for in-line maintenance.
- Easy in line maintenance.
- Anti static design.
- Stainless steel lever handle.(below 2 in.)
- Gear operated.(above 3 in.)

#### Specifications

##### Pressure Rating :

- ASME Class 150

##### End Connection

- Flanged End
- Butt Weld End

##### Materials

- ASTM A351 CF8M/CF3M Stainless Steel

#### Material of Construction

Component	Material Specification
1 Top Entry Body	ASTM A351 CF8M/CF3M
2 Spring	INCONEL X750
3 Seat Retainer	316 Stainless Steel
4 Ball Seat	PCTFE
5 Trunnion Ball	316 Stainless Steel
6 Bonnet Gasket	Graphite & 316 SS
7 Bonnet Bolt	ASTM A320 B8M. Grad 2
8 Bonnet Flange	ASTM A351 CF8M
9 Extension Bonnet	ASTM A351 CF8M
10 Extension Stem	316 Stainless Steel
11 Stem Packing	Graphite
12 Lever Handle or Gear Box	316 Stainless Steel ASTM A536 Carbon Steel

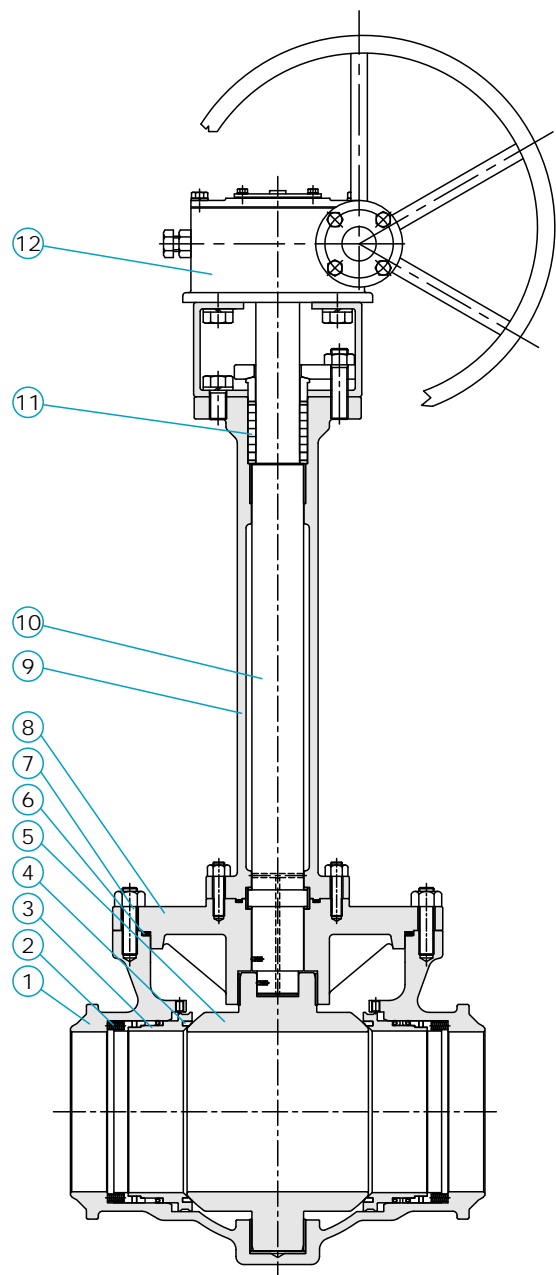

## Cryogenic Top Entry Trunnion Ball Valves

### Flange Ends

2 in. to 12 in. & Class 150

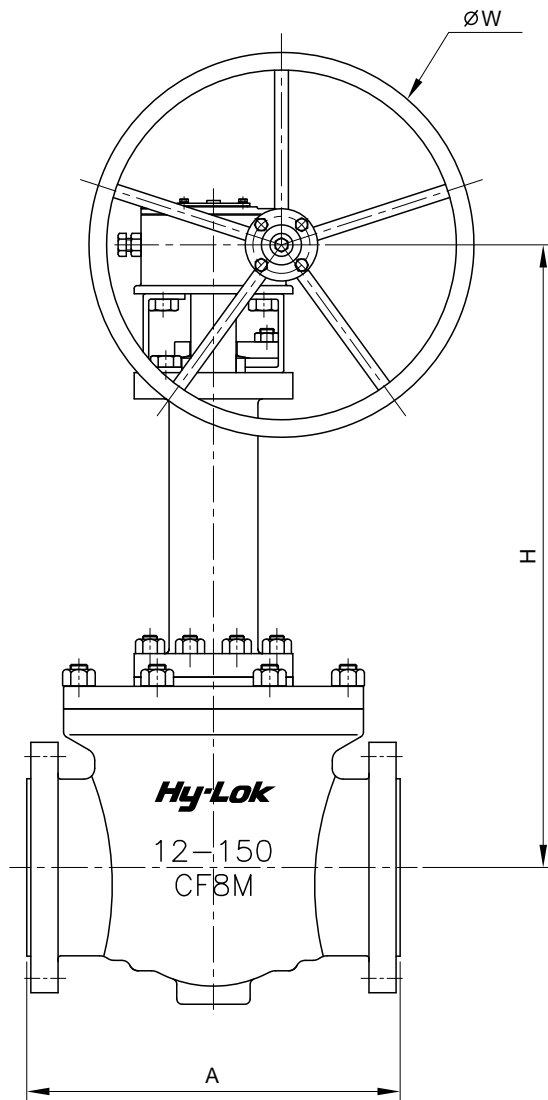

Part No.	End Connection			Dimensions (mm)				
	Size	Rating	End	A	H	Lever	W	Weight(Kg)
VCBOS- 32FA	2 in.	#150	RF	292	490	260	-	26
VCBOS- 48FA	3 in.	#150	RF	203	605		400	55
VCBOS- 64FA	4 in.	#150	RF	394	700		500	90
VCBOS- 96FA	6 in.	#150	RF	394	978		500	178
VCBOS-128FA	8 in.	#150	RF	457	1185		610	268
VCBOS-160FA	10 in.	#150	RF	568	1335		710	480
VCBOS-192FA	12 in.	#150	RF	610	1415		710	580



## Cryogenic Top Entry Trunnion Ball Valves

**Butt-weld Ends**

2 in. to 12 in. & Class 150

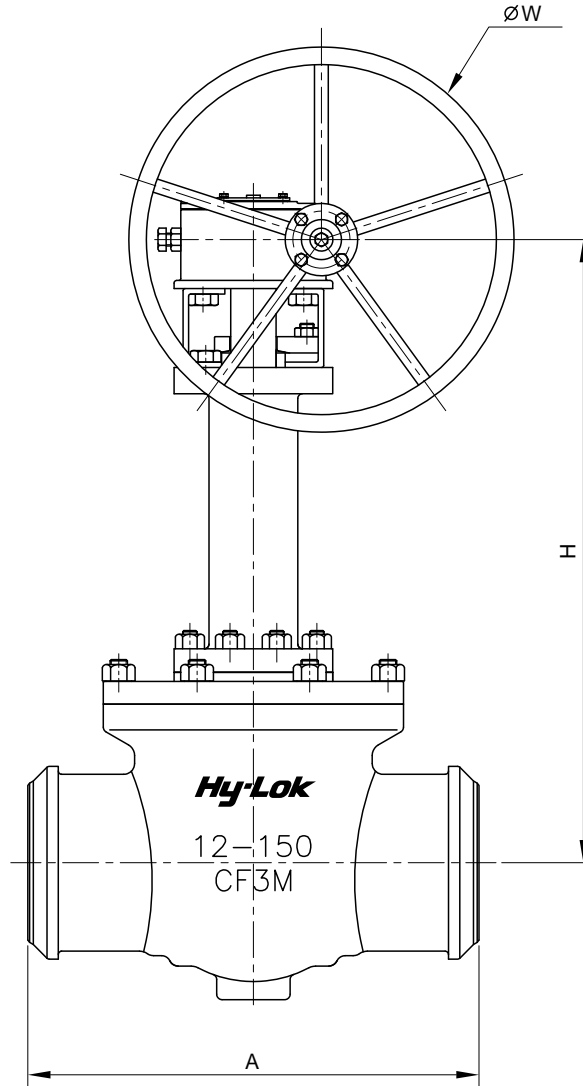

Part No.	End Connection			Dimensions (mm)				Weight(Kg)
	Size	Rating	End	A	H	Lever	W	
VCBOS- 32BWA	2 in.	#150	BW	292	490	260	-	20
VCBOS- 48BWA	3 in.	#150	BW	356	605		400	85
VCBOS- 64BWA	4 in.	#150	BW	405	800		500	115
VCBOS- 96BWA	6 in.	#150	BW	457	978		500	196
VCBOS-128BWA	8 in.	#150	BW	521	1185		610	257
VCBOS-160BWA	10 in.	#150	BW	559	1335		710	450
VCBOS-192BWA	12 in.	#150	BW	635	1415		710	580

## Cryogenic Double Block & Bleed Valve

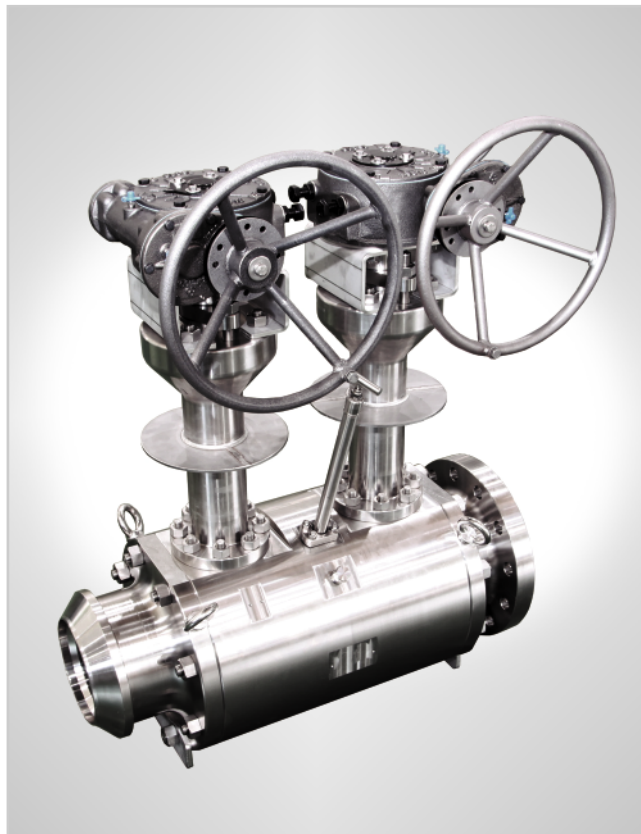

## Specifications

- 1) Valve Size : 1/2 to 6"
- 2) Applicable Rating : ASME #150 to 900
- 3) Temperature : Down to -196°C
- 4) Constructions
  - End Connection : Butt-Welded, Flanged or Screwed Type
  - Extended Bonnet
  - Floating Ball, Full Bore
  - Fire Safety Construction
  - Manual Operated
  - Uni-Direction, Two Ball & One Needle Design

# Service Network

**Hy-Lok Canada**  
CANADA / Alberta  
Tel : +1 780 409 4484  
info@hylok.ca

**Hy-Lok USA**  
USA / Houston  
Tel : +1 832 634 2000  
info@hylokusa.com

**Hy-Lok Europe**  
NETHERLAND / Amsterdam  
Tel : +31 528 23 4084  
sales@hy-lok.eu

**Hy-Lok Nigeria**  
NIGERIA / Lagos  
Tel : +234 1 7744 545  
info@hy-loknigeria.com

**Hy-Lok Middle East (Branch Office)**  
U.A.E / Dubai  
Tel : +971 4 8823018  
anzal@hy-lok.com

**Hy-Lok China**  
CHINA / Shanghai  
Tel : +86 21 6230 8533  
info@hy-lokchina.com

**Hy-Lok Singapore**  
SINGAPORE / Singapore  
Tel : +65 6 862 8811  
hylok@singnet.com.sg

**Hy-Lok Oceania**  
AUSTRALIA / Melbourne  
Tel : +61 3 9334 5700  
sales@hylok.com.au





Distributed by :

Type Approval Certificates

