



**Catalogue**  
FOOD SERVICE

**Chapter**  
COOKING

**Specific Model**  
C-E741 400V 3N 50/60Hz

19068498

31/08/2021

**DENOMINATION:**

Electric cooker with oven, 2 rounded plates, 700 range.

**DESCRIPTION :**

- Pressed surface tops manufactured in 1.5 mm thick AISI-304 stainless steel, with rounded edges, designed to prevent spilled liquid from pans from entering the interior of the oven.- Stamped surface top with rounded corners for easy cleaning.
- Laser-cut joints and automatic welding. Hidden screws.
- Cast iron hot plates,
- Power regulation via selector with 7 positions.
- Protection against overheating for each plate.
- High-temperature enamelled cast iron flue protector.
- Access to components from the front.
- Easy connection and compliant with health standards.
- Machines with IPX5 grade water protection.
  
- Static electric oven with dimensions GN 2/1.
- Heating through stainless steel heating elements with selector switch for operation of the upper and/or inner part.- Cooking chamber made entirely of stainless steel which makes cleaning easier and ensures greater hygiene.- Trays are inserted sideways which improves manoeuvrability.
- Thermostatic valve for temperature control (125 - 310 °C).
- Rails on three height levels to offer different cooking options.
- Rails with anti-tipping system to prevent trays from overturning.
- Cast iron oven floor which guarantees better performance and uniform heat distribution.- Fibreglass closing seal to improve the thermal efficiency of the oven and ensure its durability.- Stamped oven frame and inner door, ensuring a better oven closure.
- Detachable oven door to facilitate repairs.
  
- Cast iron round hot plates, 223 Ø (2.6 kW), hermetically fixed to the stamped surface top.

**POSSIBLE OPTIONS :**

- 230 1N- Transformation A 230 V single phase
- 230 III - A 230 V three-phase transformation without neutral
- MARINE - Other machines - Ship transformation - 440 III

**POSSIBLE ACCESSORIES:**

- COOKER ACCESSORIES KORE
- KORE WHEELS
- TALL CHIMNEY KORE

**DIMENSIONS**



X Width	800 mm	X Gross width	840 mm
Y Depth	730 mm	Y Gross depth	822 mm
Z Height	850 mm	Z Gross height	1255 mm
Net Weight	90,0 kg	Gross Weight	108,0 kg
Net Volume	0,50 M3	Gross Volume	0,87 M3

**ELECTRICITY TECHNICAL SPECIFICATIONS**

Electric power	16,400 KW
Amperage (A)	23,8A
Heating power	16,400 KW
Voltage	400V - 3N
Electric frequency	50/60Hz

**CONNECTIONS TECHNICAL SPECIFICATIONS**

Single-phase 230V wiring	2X25MM2+T
Three-phase +N 400V wiring	3X4MM2+T+N



**Catalogue**  
FOOD SERVICE

**Chapter**  
COOKING

**Specific Model**  
C-E741 400V 3N 50/60Hz

19068498

31/08/2021





**Catalogue**  
FOOD SERVICE

**Chapter**  
COOKING

**Specific Model**  
C-E741 400V 3N 50/60Hz

19068498

31/08/2021

**C-E741**

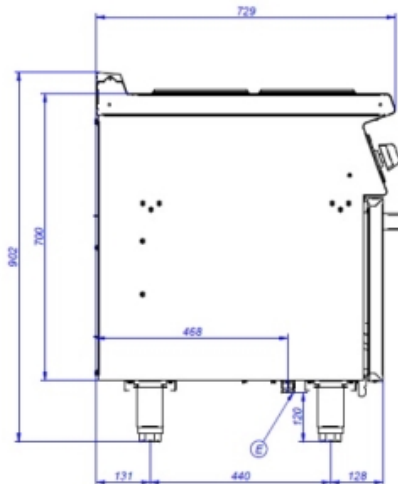
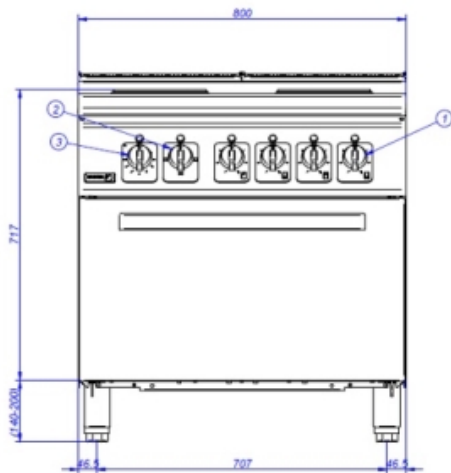

**C-E741 Q**

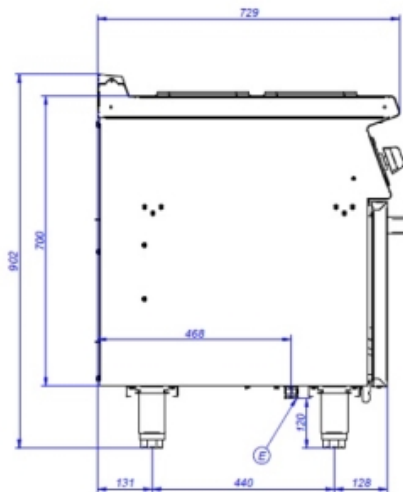
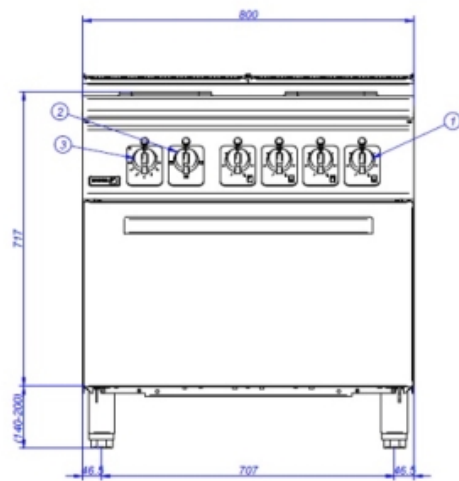

- E. Conexión eléctrica  
1. Mando placas M  
2. Mando horno 1  
3. Mando horno 2

- Electrical connection  
M plates control  
Oven control 1  
Oven control 2