



## Bring palletless handling to your operation.

*Built for fast,  
efficient and  
productive clamp  
handling.*

### APPLICATIONS

Achieve all the benefits of palletless handling of unitized loads in your manufacturing and distribution operation. Cascade's D-Series Carton Clamps allow efficient handling of a wide range of low-, medium- and high-density products including consumer paper products, appliances, consumer electronics, wine, packaged foods (canned or boxed), chemicals and plastics.

### FEATURES

- Proven arm and aluminum frame construction ensures long useful life of the clamp.
- Unique pivoting arm and stabilizer design allows superior clamping force distribution for secure and damage free handling of a wide range of product types.
- Thin arm profiles allow for stacking loads tightly in the warehouse.
- Superior arm-slide bearing material and design extends bearing life and maintains balanced clamp force distribution.
- Rubber faced aluminum contact pads are standard and provide a high coefficient of friction to securely hold loads.
- Regenerative hydraulic valving is standard for optimal arm speed.

### OPTIONS

- Application specific contact pads (sizes & surfaces)
- Quick Disconnect mounting
- Custom opening ranges
- Tilt Control
- Load Cushion



# 15 & 25D CARTON CLAMPS

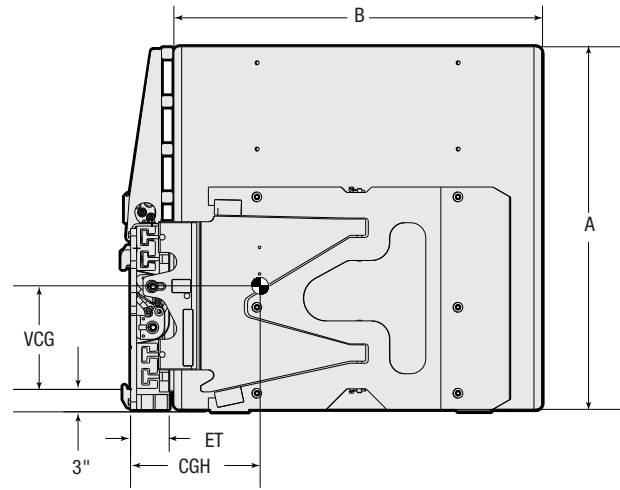
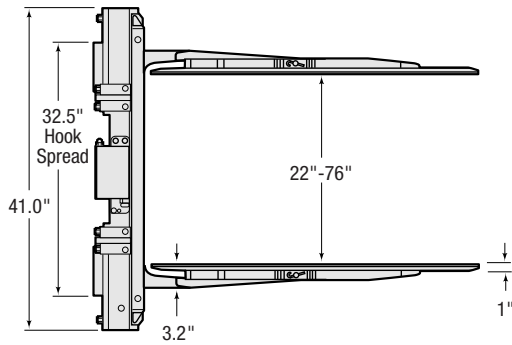

## Sideshifting

Capacity @ Load Center		Opening Range	Catalog Order No.	Mounting Class	Weight	Effective Thickness	Horizontal Center of Gravity	Vertical Center of Gravity	Arm Height	Arm Length
lbs @ inches	kg @ mm									
1,500 @ 15"	680 @ 380	22"-77"	<b>15D-CCS-01A</b>	II	1,110 / 503	5.0"	12.8"	12.9"	48"	30"
1,500 @ 15"	680 @ 405	22"-76"	<b>15D-CCS-28A</b>	II	1,295 / 588	5.0"	13.6"	13.7"	48"	32"
1,500 @ 20"	680 @ 510	22"-76"	<b>15D-CCS-32A</b>	II	1,400 / 636	5.0"	17.0"	12.8"	48"	40"
1,500 @ 21"	680 @ 535	22"-76"	<b>15D-CCS-33A</b>	II	1,415 / 642	5.0"	17.1"	12.8"	48"	42"
1,500 @ 23"	680 @ 585	22"-76"	<b>15D-CCS-34A</b>	II	1,515 / 688	5.0"	17.2"	12.6"	48"	46"
1,500 @ 24"	680 @ 600	22"-76"	<b>15D-CCS-35A</b>	II	1,535 / 697	5.0"	17.3"	12.6"	48"	48"
2,500 @ 15"	1,135 @ 380	22"-76"	<b>25D-CCS-01A</b>	II	1,255 / 570	5.0"	15.3"	13.6"	48"	30"
2,500 @ 20"	1,135 @ 510	22"-76"	<b>25D-CCS-32A</b>	II	1,400 / 636	5.0"	17.0"	12.8"	48"	40"
2,500 @ 21"	1,135 @ 535	22"-76"	<b>25D-CCS-33A</b>	II	1,415 / 642	5.0"	17.1"	12.8"	48"	42"
2,500 @ 23"	1,135 @ 585	22"-76"	<b>25D-CCS-34A</b>	II	1,515 / 688	5.0"	17.2"	12.6"	48"	46"
2,500 @ 24"	1,135 @ 600	22"-76"	<b>25D-CCS-35A</b>	II	1,535 / 697	5.0"	17.3"	12.6"	48"	48"

- ▶ Class II Bolt-On mounting is standard, Quick Disconnect mounting available.
- ▶ Class III mounting available for 25D.
- ▶ Front lower leading edge pad wear can be addressed by periodic replacement of the factory installed wear tiles. Contact Cascade Parts Department at 888-CASCADE (227-2233) for service kits. Cascade recommends using tilt control with all carton clamps.
- ▶ Can easily be converted to non-sideshifting by plugging ports on the valve.
- ▶ Attachment capacity should be matched to truck rating for most efficient application.
- ▶ Additional contact pad sizes, arm opening ranges, and features are available. Contact Cascade.
- ▶ All Carton Clamps are sideshifting.

## INSTALLATION KIT

Model	Catalog Order No.
15D/25D	659249

## HYDRAULIC FLOW AND PRESSURE

Model	Minimum Flow	Recommended Flow	Maximum Flow	Maximum Pressure
15D	5 GPM	5.5 GPM	8 GPM	2,300 PSI/160 bar
25D	5 GPM	5.5 GPM	8 GPM	2,300 PSI/160 bar

## MOUNTING CLASS INFORMATION

Mounting Class	Truck Capacity
II	2,000-5,500 lbs.
III	6,000-10,000 lbs

## HYDRAULIC FUNCTIONS

Model	Hydraulic Functions	Truck Auxiliary Valves Required
15D/25D	2	2

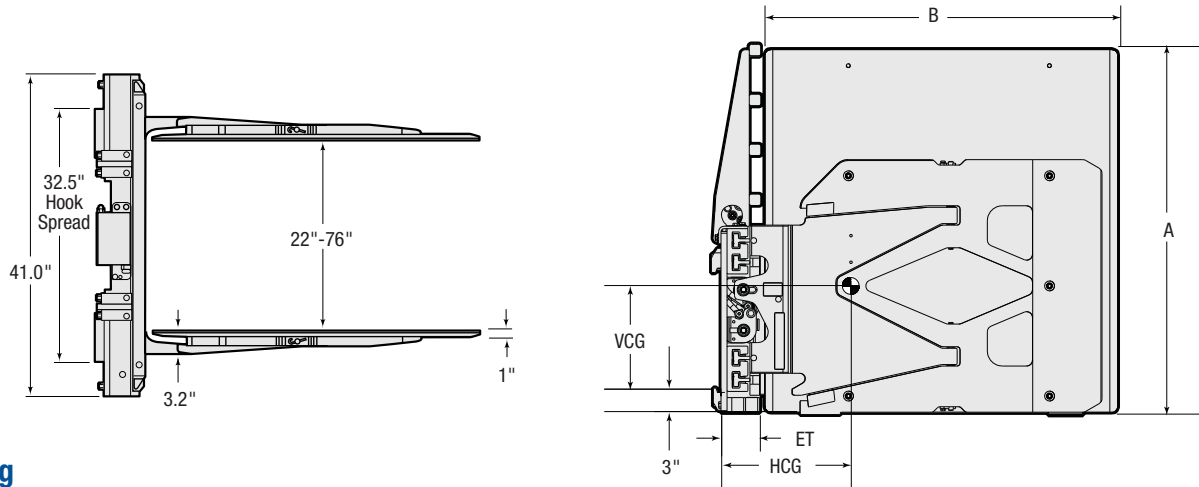

## Sideshifting

Capacity @ Load Center		Opening Range	Catalog Order No.	Mounting Class	Weight		Effective Thickness	Horizontal Center of Gravity	Vertical Center of Gravity	Arm Height	Arm Length
lbs @ inches	kg @ mm				lbs.	kg					
3,500 @ 20"	1,590 @ 510	22"-76"	<b>35D-CCS-32A</b>	II	1,400	635	5.0"	16.0	14.2	48"	40"
3,500 @ 21"	1,590 @ 535	22"-76"	<b>35D-CCS-33A</b>	II	1,410	640	5.0"	16.3	14.2	48"	42"
3,500 @ 23"	1,590 @ 585	22"-76"	<b>35D-CCS-34A</b>	II	1,530	694	5.0"	18.5	14.3	48"	46"
3,500 @ 24"	1,590 @ 600	22"-76"	<b>35D-CCS-35A</b>	II	1,540	699	5.0"	18.8	14.3	48"	48"
3,300 @ 26"	1,500 @ 660	22"-76"	<b>35D-CCS-36A</b>	II	1,650	748	5.0"	21.0	14.4	48"	52"
3,200 @ 27"	1,455 @ 685	22"-76"	<b>35D-CCS-37A</b>	II	1,660	753	5.0"	21.3	14.4	48"	54"
3,500 @ 20"	1,590 @ 510	22"-76"	<b>35D-CCS-42A</b>	II	1,440	653	5.0"	16.1	15.2	54"	40"
3,500 @ 21"	1,590 @ 535	22"-76"	<b>35D-CCS-43A</b>	II	1,450	658	5.0"	16.4	15.2	54"	42"
3,500 @ 23"	1,590 @ 585	22"-76"	<b>35D-CCS-44A</b>	II	1,580	717	5.0"	18.6	15.3	54"	46"
3,500 @ 24"	1,590 @ 600	22"-76"	<b>35D-CCS-45A</b>	II	1,590	721	5.0"	18.9	15.3	54"	48"
3,300 @ 26"	1,500 @ 660	22"-76"	<b>35D-CCS-46A</b>	II	1,700	771	5.0"	21.1	15.4	54"	52"
3,200 @ 27"	1,455 @ 685	22"-76"	<b>35D-CCS-47A</b>	II	1,710	776	5.0"	21.4	15.4	54"	54"
3,500 @ 20"	1,590 @ 510	22"-76"	<b>35D-CCS-92A</b>	II	1,480	671	5.0"	16.2	16.3	60"	40"
3,500 @ 21"	1,590 @ 535	22"-76"	<b>35D-CCS-93A</b>	II	1,490	676	5.0"	16.5	16.3	60"	42"
3,500 @ 23"	1,590 @ 585	22"-76"	<b>35D-CCS-94A</b>	II	1,620	735	5.0"	18.7	16.4	60"	46"
3,500 @ 24"	1,590 @ 600	22"-76"	<b>35D-CCS-95A</b>	II	1,630	739	5.0"	19.0	16.4	60"	48"
3,300 @ 26"	1,500 @ 660	22"-76"	<b>35D-CCS-96A</b>	II	1,740	789	5.0"	21.2	16.5	60"	52"
3,200 @ 27"	1,455 @ 685	22"-76"	<b>35D-CCS-97A</b>	II	1,750	794	5.0"	21.5	16.5	60"	54"

- ▶ Class II Bolt-On mounting is standard. Class III and Quick-Disconnect mounting also available.
- ▶ Front lower leading edge pad wear can be addressed by periodic replacement of the factory installed wear tiles. Contact Cascade Parts Department at 888-CASCADE (227-2233) for service kits. Cascade recommends using tilt control with all carton clamps. See page 6-3.
- ▶ Can easily be converted to non-sideshifting by plugging ports on the valve.
- ▶ Attachment capacity should be matched to truck rating for most efficient application.
- ▶ Additional contact pad sizes, arm opening ranges, and features are available. Contact Cascade.
- ▶ All Carton Clamps are sideshifting.

## HYDRAULIC FLOW AND PRESSURE

Model	Minimum Flow	Recommended Flow	Maximum Flow	Maximum Pressure
35D	5 GPM	7 GPM	10 GPM	2,300 PSI/160 bar

## MOUNTING CLASS INFORMATION

Mounting Class	Truck Capacity
II	2,000-5,500 lbs.
III	6,000-10,000 lbs

## HYDRAULIC FUNCTIONS

Model	Hydraulic Functions	Truck Auxiliary Valves Required
35D	2	2

## INSTALLATION KIT

Model	Catalog Order No.
35D	659249

# 50D CARTON CLAMP

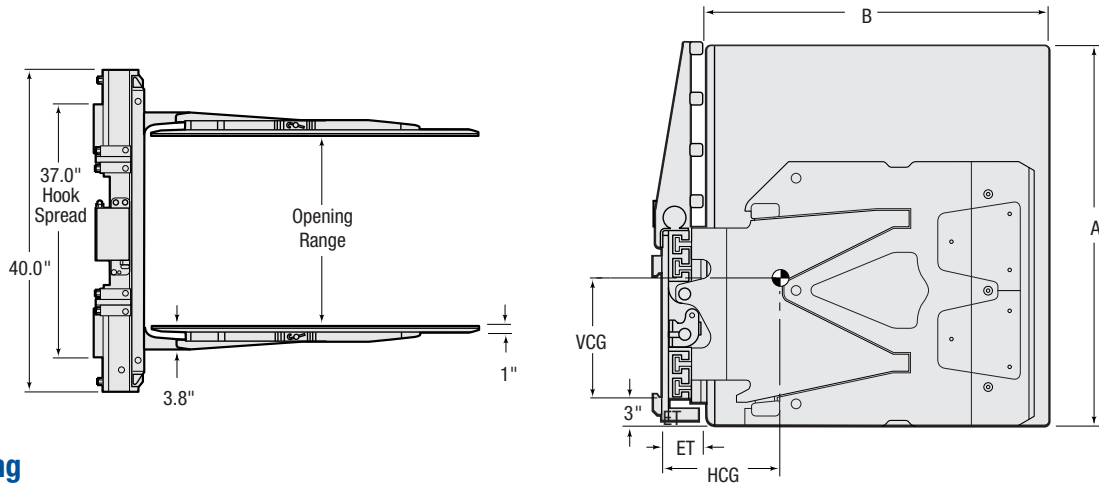

## Sideshifting

Capacity @ Load Center		Opening Range	Catalog Order No.	Mounting Class	Weight		Effective Thickness (ET)	Horizontal Center of Gravity (HCG)	Vertical Center of Gravity (VCG)	Arm Height (A)	Arm Length (B)
lbs @ inches	kg @ mm				lbs.	kg					
5,000 @ 20"	2,270 @ 510	21"-73"	<b>50D-CCS-21B</b>	III	1,980	899	6.0"	19.1"	17.8"	60"	40"
5,000 @ 21"	2,270 @ 535	21"-73"	<b>50D-CCS-22B</b>	III	1,995	906	6.0"	19.2"	17.8"	60"	42"
5,000 @ 22"	2,270 @ 560	21"-73"	<b>50D-CCS-23B</b>	III	2,005	910	6.0"	19.3"	17.8"	60"	44"
5,000 @ 23"	2,270 @ 585	21"-73"	<b>50D-CCS-24B</b>	III	2,095	951	6.0"	20.2"	16.8"	60"	46"
5,000 @ 24"	2,270 @ 600	21"-73"	<b>50D-CCS-25B</b>	III	2,110	958	6.0"	20.3"	16.9"	60"	48"

- ▶ Class III Bolt-On mounting is standard. Class II and IV and Quick-Disconnect mounting also available.
- ▶ Front lower leading edge pad wear can be addressed by periodic replacement of the factory installed wear tiles. Contact Cascade Parts Department at 888-CASCADE (227-2233) for service kits. Cascade recommends using tilt control with all carton clamps. See page 6-3.
- ▶ Can easily be converted to non-sideshifting by plugging ports on the valve.
- ▶ Attachment capacity should be matched to truck rating for most efficient application.
- ▶ Additional contact pad sizes, arm opening ranges, and features are available. Contact Cascade.
- ▶ All Carton Clamps are sideshifting.

## MOUNTING CLASS INFORMATION

Mounting Class	Truck Capacity
III	6,000-10,000 lbs
IV	10,001-17,500 lbs.

## HYDRAULIC FUNCTIONS

Model	Hydraulic Functions	Truck Auxiliary Valves Required
50D	2	2

## INSTALLATION KIT

Model	Catalog Order No.
50D	<b>659249</b>

## HYDRAULIC FLOW AND PRESSURE

Model	Minimum Flow	Recommended Flow	Maximum Flow	Maximum Pressure
50D	5 GPM	12 GPM	15 GPM	2,300 PSI/160 bar

Cascade Corporation • PO Box 20187 • Portland, OR 97294-0187 • USA • 800 CASCADE (227.2233) • Tel 503.669.6257 • Fax 800.693.3768 • Fax 503.669.6367  
 Cascade Canada Ltd. • 5570 Timberlea Blvd. • Mississauga, Ontario L4W 4M6 • Canada • 800.380.2272 • Tel 905.629.7777 • Fax 905.629.7785