



LINKHUB

Contents

Read this first	iii
Chapter 1. Meet your CPE.....	1
1.1 System requirements	1
1.2 Overview	1
Chapter 2. Get started	3
2.1 Connect your CPE to the Internet.....	3
2.2 Identify an ideal location	5
2.3 Connect the power adaptor.....	5
2.4 Access CPE network.....	5
2.5 Use the telephone function (For HH40L1 only).....	6
Chapter 3. Access the web UI	7
3.1 Log in to the web UI	7
3.2 Explore web UI features.....	7
Chapter 4. Configure your CPE.....	8
4.1 Home	8
4.2 Quick Settings.....	8
4.3 Devices Settings	9
4.4 SMS	13
4.5 Firewall.....	13
4.6 System settings.....	14
Important safety information.....	16
Important safety instructions	16
Medical device interference	16
Power adapter	16
Battery.....	16
Operating temperature.....	17
Troubleshooting	18

Read this first

- Before using this documentation and the device it supports, ensure you read and understand the "Important safety information" on page 17.
- Illustrations in this documentation might look different from your device.
- Instructions in this documentation may vary depending on your device model and software version.
- Some features are not available in all countries or regions. Feature availability is subject to change.
- Documentation content is subject to change without notice. We make constant improvements on the documentation of your device, including this user manual.
- TCL Communication Ltd. does not assume any liability that may occur due to the use or application of the product described herein. Every effort has been made in the preparation of this documentation to ensure accuracy of the contents, but all statements, information and recommendations in this documentation do not constitute the warranty of any kind, express or implied.

Chapter 1. Meet your CPE

This TCL CPE is a 4G LTE mobile router, providing download speeds of up to 150 Mbps. Your CPE lets you create fast and secure Wi-Fi in any location with cellular network coverage.

1.1 System requirements

Your CPE supports up to 32 connected devices with 2.4 GHz Wi-Fi network (802.11b/g/n). It also works with a range of browsers, including: Firefox, Safari, Internet Explorer, Opera, and Google Chrome.

1.2 Overview

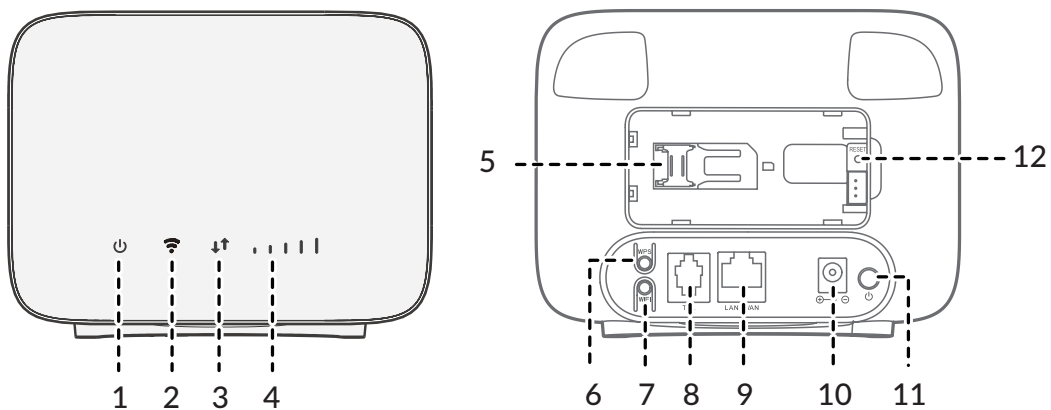

1. Power indicator	<ul style="list-style-type: none">• Solid yellow: The battery is low.• Blinking blue: The device is charging.• Solid blue: The battery has enough power; fully charged; connect the adaptor when the battery has been removed.• Off: The device is off.
2. Wi-Fi/WPS indicator	<ul style="list-style-type: none">• Blinking blue: WPS connection is available.• Solid blue: Wi-Fi is enabled.• Off: Wi-Fi is disabled.
3. Network indicator	<ul style="list-style-type: none">• Blinking blue and red: Target tariffs are exceeded.• Solid blue: The device is connected to the network.• Solid red: Micro SIM card is not available or the device is not registered to the network.
4. Signal indicator	<ul style="list-style-type: none">• The more blue signal bars are visible, the stronger the signal.• Off: No signal.
5. Micro SIM card slot	Insert a micro SIM card in the slot.

6. WPS button	Press the button for 3 seconds to enable the WPS function. The WPS function will be automatically disabled if a WPS connection is not established within 2 minutes.
7. Wi-Fi button	Press the button for 3 seconds to disable/enable your CPE Wi-Fi. This function is enabled by default. When this function is disabled, other users cannot detect the SSID or the Wi-Fi name.
8. Telephone port (For HH40L1 only)	Connect a telephone to make or answer calls.
9. LAN/WAN port	For connecting with an internet source or wired devices such as computers or switches.
10. Power connector	For connecting with the power adapter.
11. Power button	Press the button to power on/off your device.
12. Reset button	Use a paperclip to press the button for 3 seconds to reset the device.

Chapter 2. Get started

This chapter introduces the basic instructions on how to get your CPE up and running. The instructions may vary depending on your CPE model.

2.1 Connect your CPE to the Internet

The device can only connect with the network in one way at a time. Depending on the method you choose, you must perform the corresponding configuration.

Method one: via cellular network

1. Remove the back cover.

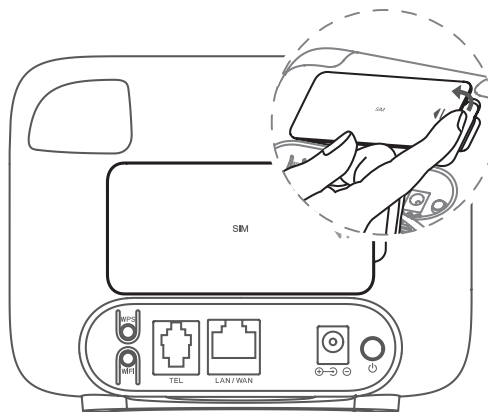

NOTE

Before using your router, record the default Wi-Fi name, Wi-Fi password and web UI login information printed on the label inside your router.

2. Install a SIM card.
Select the right size of SIM card for your CPE.

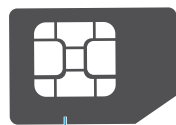

Mini-SIM (2FF) ❌

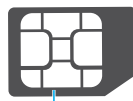

Micro-SIM (3FF) ✅



Nano-SIM (4FF) ❌

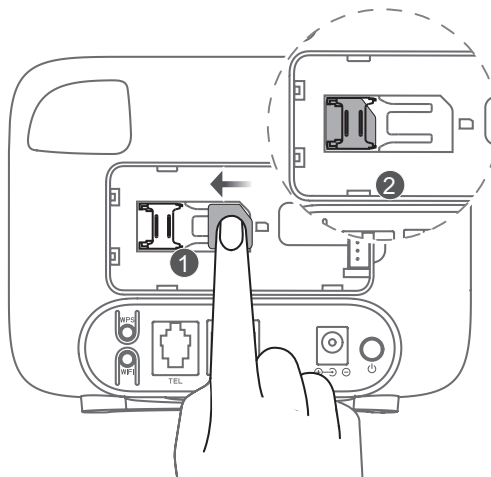

Be aware of the orientation of the SIM card. If the SIM card is inserted incorrectly, it may get jammed.

3. Install the battery.

Ensure that the pins from the battery are aligned with the pins beside the reset button of your device.

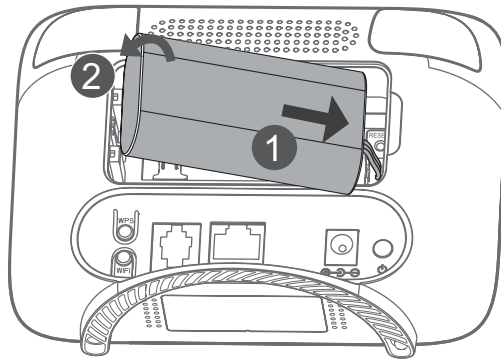

4. Re-attach the back cover.

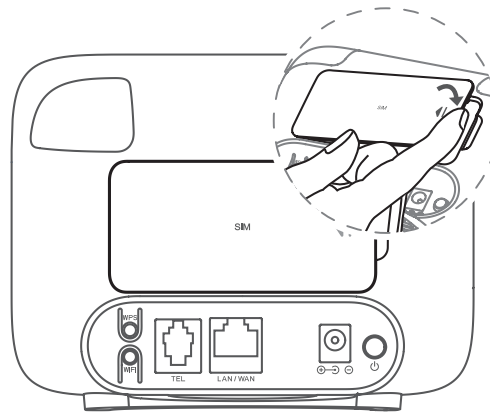

Method two: via broadband connection

If you want to access the Internet via a wired broadband connection, you need to plug a network cable into the WAN/LAN port.

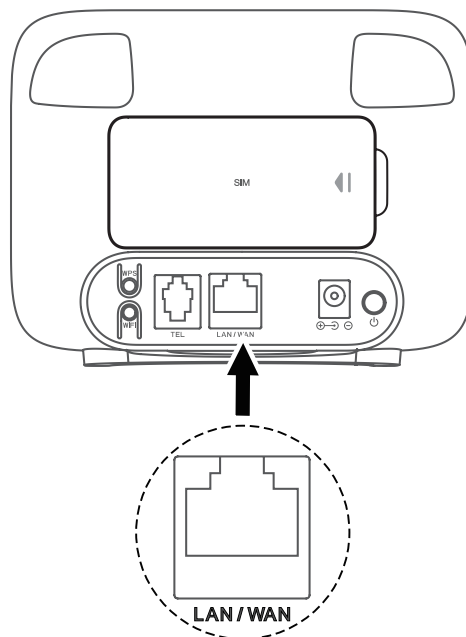

2.2 Identify an ideal location

Identify an ideal location for your 4G CPE. To make the most of your CPE, make sure the location meets the following criteria:

- Near a window
- A cool, dry and well-ventilated area away from objects such as walls and electrical appliances
- Near a power outlet
- On a sturdy and flat surface

2.3 Connect the power adaptor

Follow the illustration below to plug in the power adaptor.

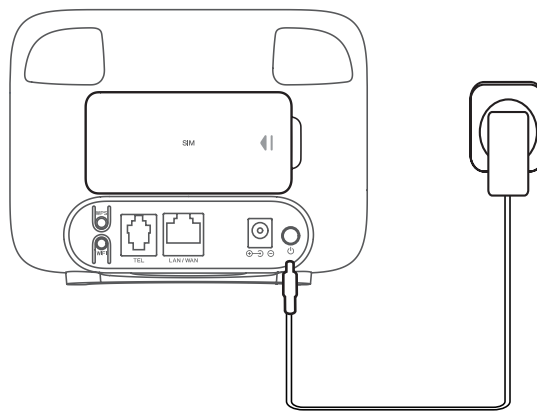

2.4 Access CPE network

You can link your devices to the CPE network using wired or wireless connections as illustrated below.

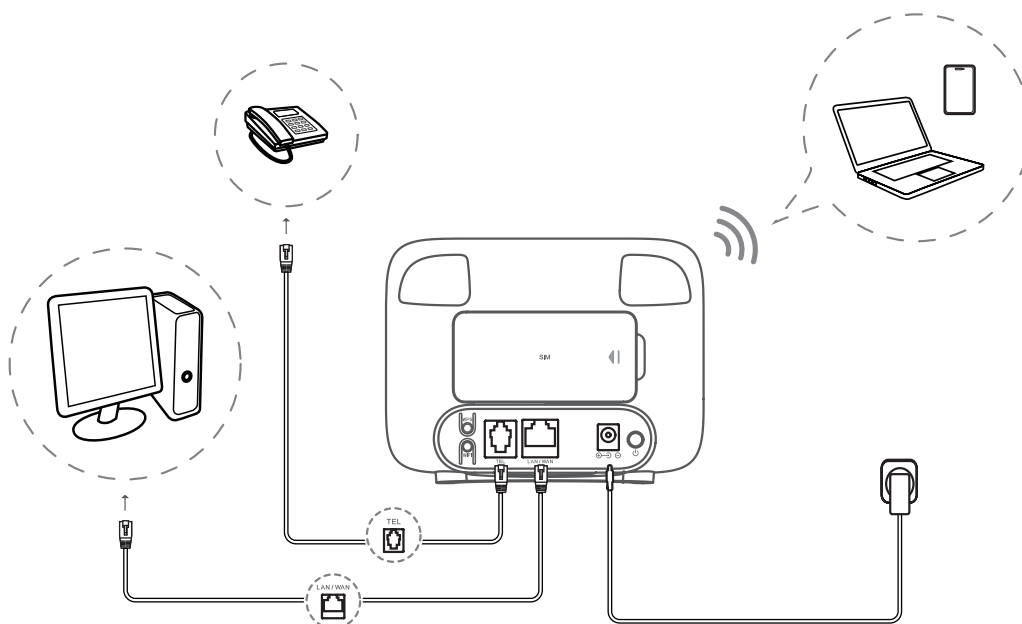

If your wireless device is WPS-enabled, you can also access the CPE Wi-Fi network through a WPS connection. Select one of the following options to make a WPS connection.

Option 1: WPS button

1. Press the WPS button on your CPE for 3 seconds.
2. Enable the WPS function of your wireless device within 2 minutes to make a WPS connection.

Option 2: PBC

1. Log in to the web user interface (UI) of your CPE, and go to [Devices settings](#) > [Wi-Fi settings](#). (For more information on how to log in to the web UI, see "Chapter 3. Access the web UI" on page 7.)
2. Choose [Enabled](#) for WPS switch, and click [Apply](#).
3. Go to [Add new devices](#) and choose PBC; enter the new device information you want to connect to the CPE. Click [Apply](#).

Option 3: WPS PIN code

1. Log in to the web user interface (UI) of your CPE, and go to [Devices settings](#) > [Wi-Fi settings](#). (For more information on how to log in to the web UI, see "Chapter 3. Access the web UI" on page 7.)
2. Choose [Enabled](#) for Current PIN switch, and click [Apply](#).
3. Check the PIN code from the Current PIN.
4. Enter the PIN code when the device attempts to connect to the CPE. Click [Reset PIN code](#) to reset the PIN code, you can find the default PIN code from the label located on the bottom of the device. Click [Random PIN code](#) to change the PIN code.

2.5 Use the telephone function (For HH40L1 only)

Your CPE supports telephone functionality. Connect a telephone to your CPE using a telephone cable as illustrated below.

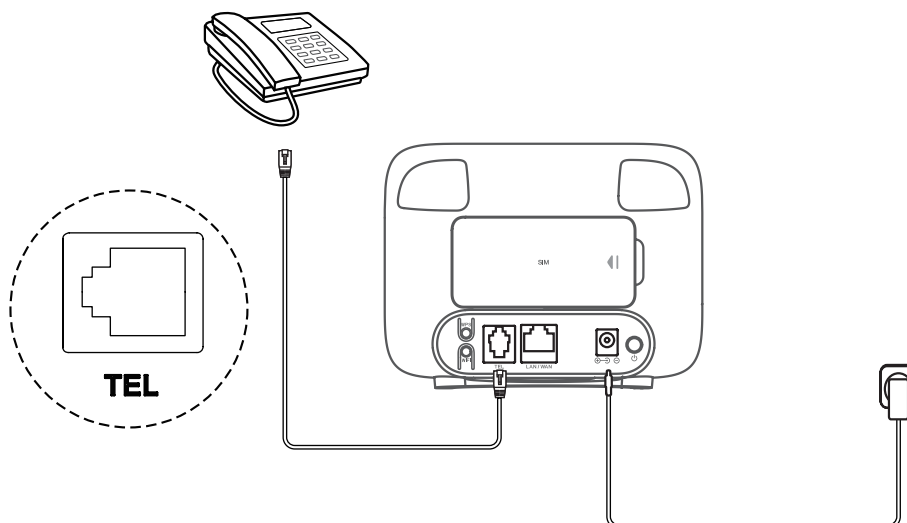

Chapter 3. Access the web UI

This chapter provides information on how to get access to the web UI of your CPE, and gives you a glimpse of the web UI.

3.1 Log in to the web UI













To log in to the web UI, follow these steps:

1. Open a web browser on the device connected to the CPE network.
2. Go to <http://192.168.1.1>, then follow the on-screen instructions to finish the login process. For the default login information, refer to the label inside your CPE.

3.2 Explore web UI features

The home page of the web UI is mainly comprised of the following tiles: [Connection](#), [Usage](#), [SMS](#), [Settings](#), and [More](#). Click on each tile to display more information.

Commonly-used status icons are displayed in the web UI, which provide information about your CPE.

Status icon	What it means
	The device is charging
	Full power or connected to the adaptor
	The number of signal bars indicates the signal strength. The more signal bars it shows, the stronger the signal is.
	No signal / no server
	The CPE is connected to the WAN network.
	The CPE is connected to the broadband network
	The CPE is disconnected from the WAN network.
	The CPE is connecting to the network.
	New messages
	Valid SIM card
	No SIM card / incorrect SIM card
	The number of users connected to your CPE network

Status icon	What it means
	The CPE Wi-Fi is off
VoLTE	The VoLTE function is enabled (For HH40L1 only)
VOIP	The VOIP function is enabled (For HH40L1 only)

Chapter 4. Configure your CPE

In this chapter, we will show you how to get the most out of your CPE using the web UI. With the web UI, you can configure Wi-Fi settings, view connected devices, manage SMS settings, and more.

4.1 Home

On the Home page, you can configure the basic information for your CPE, including Internet, Statistics, Advanced, DHCP, Home network and Wi-Fi settings.

Internet

Internet allows you to view your device information including IMEI, IMSI, LAN Domain, WAN IP address and WAN IPv6 address.

Statistics

Internet statistics can be seen here, both for your current session and your total traffic for the month. You can also reset the statistics from here.

Advanced

The advanced selection shows the firmware version and the signal quality data.

DHCP

DHCP allows you to view the IP address you have defined and which will be automatically assigned to the connected devices.

Home network

You can find how many devices are currently connected by either Wi-Fi or cable.

Wi-Fi

The Wi-Fi network information such as SSID, max access number, MAC address and band.

4.2 Quick Settings

The wizard will show you how to set up basic gateway safety parameters: Click [Previous](#) or [Next](#) to navigate, and click [Apply](#) to save settings. Advanced parameter settings can be accessed via other menus.

Network Name (SSID)	SSID is the name of the Wi-Fi network.
SSID Broadcast	This function is enabled by default. When this function is disabled, other users cannot detect the SSID or the Wi-Fi name. They need to manually enter the SSID and password to connect to your CPE network.
Security Mode	The available security modes include OPEN , WPA2-PSK(AES) and WPA/WPA2-PSK(TKIP/AES) .

Pass Phrase	Set a password for your Wi-Fi network.
--------------------	--

4.3 Devices Settings

Connected Devices

Click [Connected Devices](#) to get more detailed information on the connected devices. In the details page, you can edit the names of connected devices.

Advanced Settings

DHCP	Dynamic Host Configuration Protocol (DHCP) is a client or server protocol that automatically provides you with an Internet Protocol (IP) host. With DHCP Server enabled, the IP address and subnet mask you have defined will be assigned to the connected devices automatically.
USSD	Enter the USSD code and click Send. Call your operator to get the command code.
PIN Management	<p>Enable SIM PIN:</p> <ol style="list-style-type: none"> 1. When the SIM PIN feature is disabled, click Enable. 2. Set a SIM PIN code that is 4 to 8 digits long. 3. Click Apply. <p>Disable SIM PIN:</p> <ol style="list-style-type: none"> 1. When the SIM PIN feature is enabled, click Disable. 2. Enter the current SIM PIN code. 3. Click Apply. <p>NOTE: When the SIM PIN code is entered incorrectly 3 times, a PUK code is required. You can obtain the PUK code by calling the customer services of your SIM card.</p>
Static IP	Setting static IP address binding can bind the computers IP address with the MAC address, effectively preventing ARP attacks. After binding, there is a one-to-one correspondence between the computer IP address and the MAC address. Others cannot steal the computer IP address through ARP attacks, and you can use the network normally.
Static Routing	A static route is a manually configured route which is simple, efficient, and reliable. Appropriate static routes help reduce route selection problems and data overload of route selection, improving the packet forwarding speed.

DDNS	<p>A WAN IP address is needed when some functions of your CPE are enabled. If the WAN IP address of your CPE changes, these functions may not work properly.</p> <p>The Dynamic Domain Name Server (DDNS) function allows you to map a dynamic WAN IP address (public IP address) to a static domain name, helping Internet users (WAN side) to access the CPE network via a static domain name.</p>
Cell Locking	Lock the CPE's network to a physical cell or frequency.
FOTA upgrade	<p>After clicking Check, your CPE will check if an update is available. If one is found, you can click Download. Once the file has been downloaded successfully, you can click Update.</p> <p>Note: Do not power off your router during the update process as this may damage the device.</p>

Internet Settings

Network Selection

You can set the network mode to [4G only](#), [3G only](#), [2G only](#) or [4G/3G only](#). Make sure that you click [Apply](#) after making any changes.

APN

On this tab, you can set up a new APN profile, and edit or delete existing profiles.

Add a new profile	<ol style="list-style-type: none"> 1. Click Add New. 2. Input the correct parameters (e.g. profile name and APN) for your network operator. 3. Click Save.
Edit a profile	<ol style="list-style-type: none"> 1. Select the profile from the profile management list. 2. Click Edit to set the parameters. 3. Click Save.
Delete a profile	<ol style="list-style-type: none"> 1. Select the profile from the profile management list. 2. Click Delete. <p>NOTE: The default profile cannot be deleted.</p>
Set as default	<ol style="list-style-type: none"> 1. Select the profile from the profile management list. 2. Click Set Default.

WAN Mode

Set your CPE to access the Internet.

Mode 1: cable (plug the ethernet cable from the Internet into the WAN port of your CPE.)

Set up the WAN connection mode and modify related parameters under this option. You can set the connection mode to [Dynamic IP](#), [Static IP](#) or [PPPoE](#).

Dynamic IP	Click Apply . The IP address and related configuration settings such as subnet mask and default gateway are all automatically assigned.
Static IP	Access the Internet using a fixed IP address, subnet mask, gateway IP address and Primary DNS server. This information should be provided by your network service provider.
PPPoE	Point-to-Point Protocol over Ethernet (PPPoE) is a network protocol that is mainly used for DSL services whereby individual users connect to a modem using an ethernet connection. Enter the account number and password provided by your network service provider, and click Apply .

Mode 2: 4G

Connect the CPE via cellular network. For details, see '2.4 Access CPE network' on page 5.

Roaming

You can connect to the roaming network of this CPE when this function is enabled. It's disabled by default.

Statistics Settings

With this feature, you can set your billing day, monthly data plan, time limit, etc. Click [Apply](#) after making the preferred changes.

Wi-Fi Settings

Wi-Fi Switch

Select [Enabled](#) to enable the Wi-Fi function, and [Disabled](#) to disable it.

SSID Settings

You can set three SSID presets (Main SSID, SSID1 and SSID2); click [Apply](#) after making any changes.

Network Name (SSID)	SSID is the name of the Wi-Fi network.
SSID Broadcast	This function is enabled by default. When this function is disabled, other users cannot detect the SSID or the Wi-Fi name. They need to manually enter the SSID and password to connect to your CPE network.
Security Mode	The available security modes include OPEN , WPA2-PSK(AES) and WPA/WPA2-PSK(TKIP/AES) .

WPS Settings

WPS is a wireless network security standard that tries to make connections between your CPE and wireless devices faster and easier.

If your wireless device is WPS-supported, you can access the CPE Wi-Fi network through a WPS connection.

WPS Switch	Select Enabled to enable the WPS function, and Disabled to disable it.
Add new device	There are two ways to add a new device, you can choose PIN or PBC ; for details see '2.4 Access CPE network' on page 5.

MAC Filter

Set MAC address filtering mode in the WLAN MAC Filter drop-down list box.

Ruleless: Disable the WLAN MAC filter.

White List: Allow a client to connect to the device using the WLAN if the clients MAC address exists in the MAC Address list.

Black List: Deny a client's connection to the device using the WLAN if the clients MAC address exists in the MAC Address list.

Advanced Settings

Network Mode	The mode is set to 802.11b/g/n by default.
Channel Bandwidth	You can select from the available options via the drop-down menu. This is set to Auto by default.
Country/Region Code	You can select the appropriate country/region code for your device.
Frequency (Channel)	Select the appropriate channel to optimise the performance and coverage of your wireless network. This is set to Auto by default.
DCS	The DCS option for dynamic channel adjustment is only available when automatic channel is selected.

Voice Settings (For HH40L1 only)

SIP ALG (Session Initialisation Protocol Application Layer Gateways)

This helps the private network terminal equipment under NAT to perform normal data exchange with the SIP softswitch on the public network, without making any changes. You can set the port and click **Apply** to save the setting once the function is enabled.

WB mode

You can switch between broadband and narrowband mode on voice call with this function. Select **Enabled** to use broadband for voice call, and select **Disabled** to use narrowband.

VoLTE APN (Voice over Long-Term Evolution Access Point Name)

VoLTE is a high-speed wireless communication standard for mobile phones and data terminals. Its main purpose is to provide a shorter connection waiting time, as well as higher quality and more natural voice and video call effects. The VoLTE APN is **IMS** as default.

Digitmap settings

DigitMap is a dial plan that exists in the media gateway to detect and report dial events of the terminal. When the number dialled conforms to one of the dial plans defined by DigitMap, the media gateway sends the called number to the core network. If the called number dialled by

the calling party does not conform to any of the dialling plans defined by DigitMap, the media gateway will directly release the call and send an empty number prompt tone to the calling party. This function is [Disabled](#) by default.

Hotline settings

Enter the hotline number and click [Apply](#), to enable one-touch dialling according to your settings.

Line reversal

Line reversal on the telephone port. This function is [Disabled](#) by default.

SIP server

SIP server (Session Initiation Protocol) is a proxy server which provides advanced telephone services across the Internet. Contact your SIP operator to get information such as account and password.

Voice call

Select the voice call mode here. The SIM card is set as the default mode for voice calls, and network call mode is set as the default when VOIP is chosen.

4.4 SMS

In this section, click [Device](#) to check the messages saved in the device; click [SIM](#) to check the messages saved in the SIM card.

Refer to the following table for commonly used SMS message operations.

Read a message	Click on the message to expand it.
Send a message	<ol style="list-style-type: none">1. Click New.2. Input the recipient's number and message content.3. Click Send.
Reply to a message	<ol style="list-style-type: none">1. Click the message you want to reply to.2. Input the message content, then click Send.
Delete a message	<ol style="list-style-type: none">1. Tick the box in the far left column for the message(s) that you wish to delete.2. Click Delete.
Delete all messages	<ol style="list-style-type: none">1. Tick the box at the top left.2. Click Delete.
Refresh the inbox	Click Refresh to refresh the inbox.

4.5 Firewall

Port filtering

This function is [Disabled](#) by default, any device connected to your CPE is allowed to access

the Internet. You can use the Port filter to block specific devices from accessing the Internet.

Disable: All connected devices can access the Internet.

Enabled: Devices with a MAC/IP/Port address added to this list cannot access the Internet.

Port mapping

Port mapping enables a host's internal network (LAN) IP address become mapped on to a public network (WAN) IP address. Port mapping can also be used to map multiple ports of an external network IP address machine to different ports on different machines in the internal network. This function is **Disabled** by default.

Port Forwarding

This function enables external users to access FTP and other service within the LAN. This function is **Disabled** by default.

URL filtering

In this feature, you can set Internet access schedule for the devices on the CPE network, and define which websites the devices cannot visit.

UPnP

Universal Plug and Play (UPnP) is a set of networking protocols that allows connected devices to discover each other and establish functional network services for data sharing, communications, and entertainment. This function is **Disabled** by default.

DMZ

If external users cannot access certain network services within the LAN, you can enable the DMZ function and set a new host IP address. This function is **Disabled** by default.

Rate limiting

Rate limiting is to limit the download/upload speed of accessing your CPE. This function is **Disabled** by default.

4.6 System settings

System settings

Time setting

Current local time	Display the current year, month, day, time, and day of the week.
Time set mode	This function is SNTP auto synchronization by default.
SNTP server	SNTP (Simple Network Time Protocol) is a networking protocol for clock synchronisation between computer systems over packet-switched data networks. You can specify which SNTP servers to use.
Time Zone	Set the time zone in the drop-down menu.

Daylight saving time

Daylight saving time is a system for automatically specifying local time. The unified time adopted during the implementation of this system is called "daylight saving time". This function is [Disabled](#) by default.

Modify password

Enter the current password, set the new username and password and click [Apply](#).

Restore factory setting

If you can't access the Internet for unknown reasons, or have forgotten the login password, you can restore the CPE to factory settings.

Network tools

Ping

Ping (Packet Internet Groper) is an Internet packet explorer, a program used to test the amount of network connections. Ping is mainly to send ICMP (Internet Control Message Protocol Internet Message Control Protocol) Echo request messages to a specific destination host to test whether the destination station is reachable and to understand the status of its relationship.

Count: The number of attempts to connect.

URL or IP: The web address you want to connect to.

Trace

URL or IP: The web address you want to debug.

System upgrade

Click [Browse](#) to choose the file package for upgrading the system you have downloaded, click [Upload](#) to update the device software.

Reboot

Click [Reboot](#) to reboot the device.

Important safety information

Read all the safety information before using your product. Failure to follow these safety instructions could result in injury, or damage to your product or other property.

Important safety instructions

- Do not use the device in areas where wireless devices are prohibited.
 - Do not let children use the device and its accessories without supervision.
 - Always handle your device with care, and keep it in a clean and dust-free place.
 - Do not attempt to repair the device yourself.
 - Do not drop, throw, or bend your device.
 - Do not dispose of the device and its accessories in a fire.
-

Medical device interference

Your router contains components which may interfere with medical devices such as pacemakers, defibrillators, or other medical devices. Maintain a safe distance of separation between your medical device and your router. Consult your physician and medical device manufacturer for information specific to your medical device.

Power adapter

Charge your device with the supplied USB cable. Only charge with an adapter that is compliant with the applicable international and regional safety standards. The adapter should be CE-approved. Using other adapters could cause damage to the device or pose a risk of injury or death. Keep the adapter in a well-ventilated area when it is plugged into an electrical outlet. Don't use damaged power adapters.

Battery

CAUTION Risk of explosion if battery is replaced by an incorrect type. Dispose of used batteries according to the instructions.

In accordance with air regulations, the battery of your product is not fully charged. Please charge it first.

- Do not attempt to open the battery (due to the risk of toxic fumes and burns).
- Do not puncture, disassemble, or short circuit the battery.
- The battery must be recycled or disposed of separately from household waste. Dispose of batteries according to your local environmental laws and guidelines.
- Replace the battery only with another qualified battery. Use of an unqualified battery may present a risk of fire, explosion, leakage, or other hazard.
- Do not use a damaged battery.

Operating temperature

Your device is designed to work best in ambient temperatures between 0 °C and 40 °C (32 °F and 104 °F), and should be stored in ambient temperatures between -20 °C and 70 °C (-4 °F and 158 °F). Your device may malfunction if operated or stored outside of these temperature ranges. Avoid exposing the device to dramatic changes in temperature or humidity.

Troubleshooting

If you encounter problems while using the product, use the troubleshooting information to help determine the problem and find possible solutions.

General problems

Problem	Solution
I've forgotten the Wi-Fi password.	<ul style="list-style-type: none">• Log in to the web UI, then go to Devices Settings > Wi-Fi Settings > SSID Settings > Display Password, and find the current Wi-Fi password.• Or you can also simultaneously press the power button and WPS button for 3 seconds to restore the device to its factory settings.
How do I change the Wi-Fi name and password?	<ol style="list-style-type: none">1. Log in to the web UI.2. Go to Devices Settings > Wi-Fi Settings > SSID Settings.
I can't find the Wi-Fi name on my wireless device.	<ul style="list-style-type: none">• Make sure the Wi-Fi signal LED is solid blue.• Refresh the available network list on your wireless device.
How do I set a new PIN code for my SIM card?	<ol style="list-style-type: none">1. Log in to the web UI.2. Go to Settings > PIN Code Settings.3. Enable PIN Code Operation, and enter a new PIN code.4. Click Apply.
Where can I find the device name and firmware version?	Log in to the web UI. You can find the related information on the home page.

Web UI problems

Problem	Solution
How can I access the web UI?	<ol style="list-style-type: none">1. Open the web browser, and go to http://192.168.1.1.2. Enter the login information as required. Find the default login information on the label inside your CPE.
I can't log in to the web UI.	<ul style="list-style-type: none">• Make sure 192.168.1.1 is entered correctly in the web browser.• Make sure the CPE is powered on.• Check whether the device is connected to the CPE network properly.

How do I change the login password?	<ol style="list-style-type: none"> 1. Log in to the web UI. 2. Go to System Settings > System Settings > Modify Password.
"No SIM card" or "Invalid SIM card" is displayed on the web UI.	<ul style="list-style-type: none"> • Make sure there is a SIM card in your CPE. • Reinstall the SIM card, and log in to the web UI again. <p>NOTE: Power off your device before removing the SIM card.</p>

Connection problems

Problem	Solution
I can't access the Internet.	<ul style="list-style-type: none"> • If no SIM card is detected, power off your CPE, and reinstall the SIM card, then try again. • If a PIN code is required, enter the PIN code, and try again. • If no network is available, place the CPE in an area with a better signal (for example near a window), and try again. • Reboot your CPE by pressing the power button for 10 seconds, and try again. • If the MAC filter function is enabled, make sure your device's MAC address is not blocked in the MAC filter settings.
How can I connect to the CPE network?	<p>Select the Wi-Fi name (or the SSID) of the CPE on your wireless devices, and enter the Wi-Fi password.</p> <p>NOTE: Find the default Wi-Fi name and password on the label inside your CPE.</p>
"PIN lock" or "PUK lock" is displayed on the screen of the device connected to the CPE network.	<p>This indicates that the SIM card is locked.</p> <p>To unlock the SIM card, log in to the web UI and enter the PIN code or PUK code. To obtain the PUK code, contact your internet service provider.</p> <p>NOTE: If the PIN code is entered incorrectly 3 times, you will be required to enter the PUK code. If the PUK code is entered incorrectly 10 times, the SIM card will be locked permanently.</p>