

CraftHaus

Missile Launcher Truck





CraftHausz



The missile vehicle is not an ordinary truck, but a heavy-duty special combat platform specifically designed for Dongfeng ballistic/cruise missiles, capable of completing the entire process of storage, transportation, erection, and launch in one vehicle. It is mainly composed of China's independently developed multi-axle heavy off-road chassis + launch canister + hydraulic system + command control/communication navigation modules. It is the core equipment for the Rocket Force's road mobile launch, commonly referred to by netizens as the mobile carrier of "Dongfeng Express."



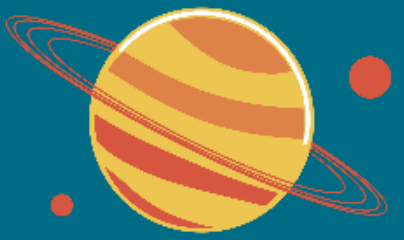

Identifying Materials

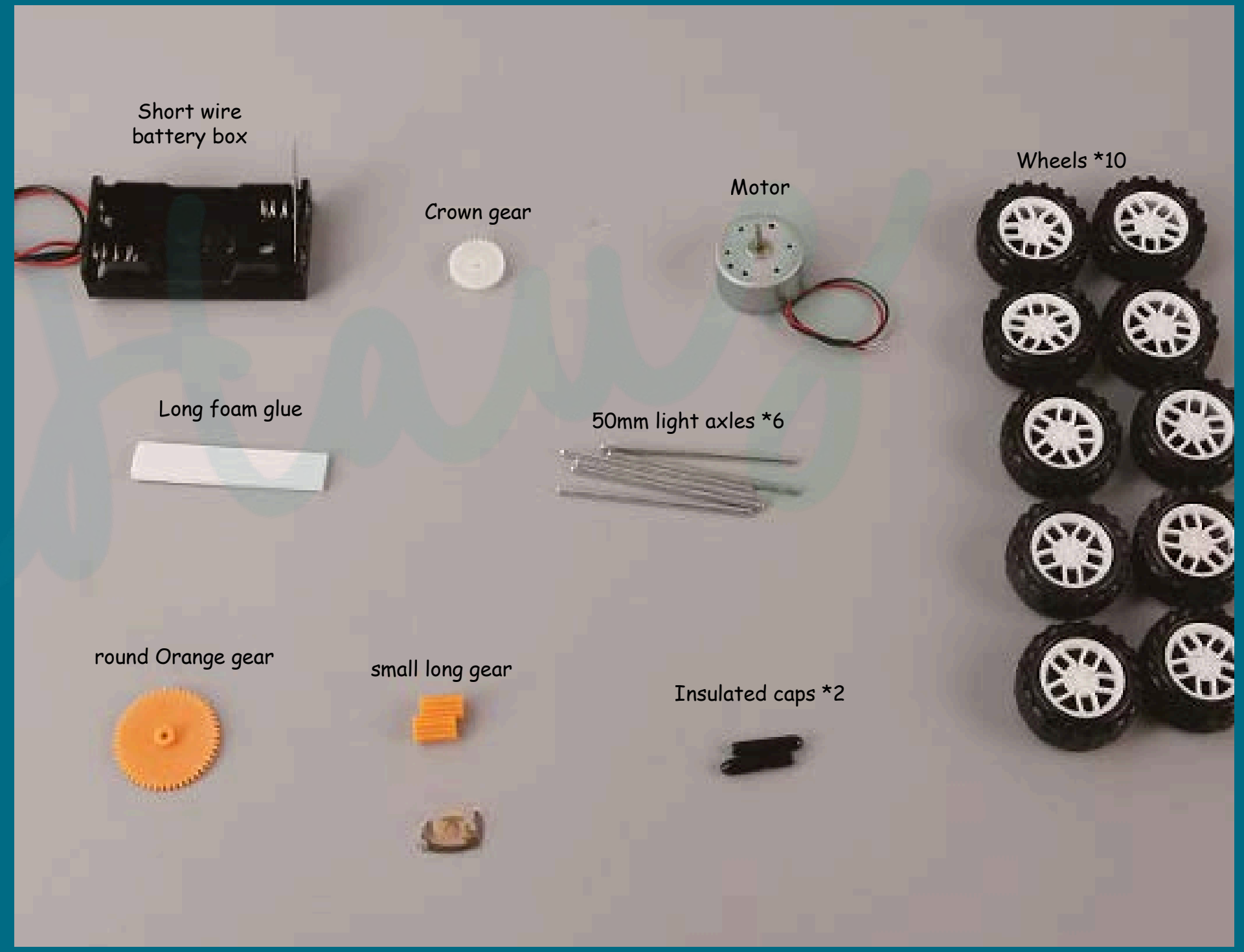
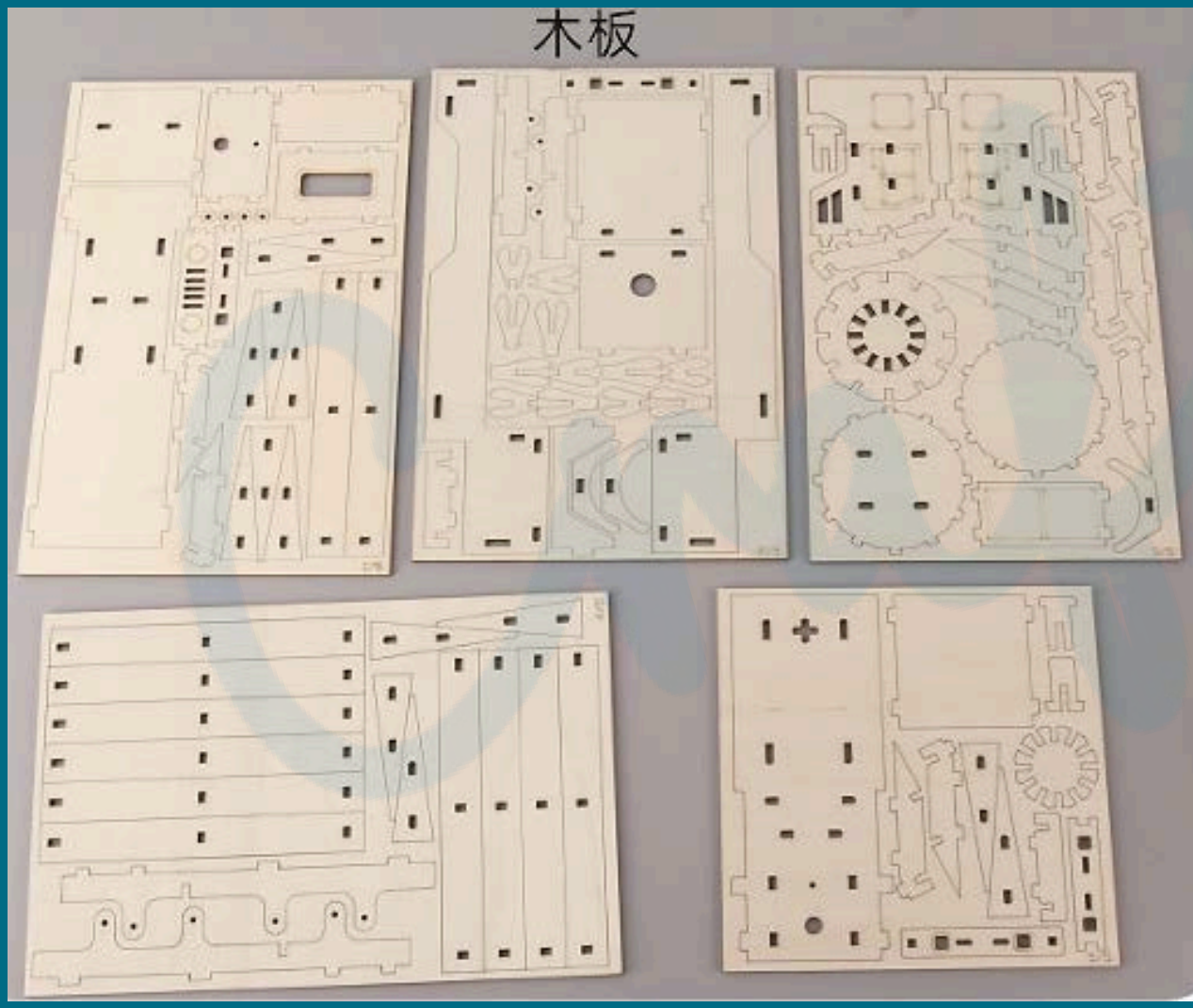



Prepare the above materials as shown
Install wooden boards and motor as shown

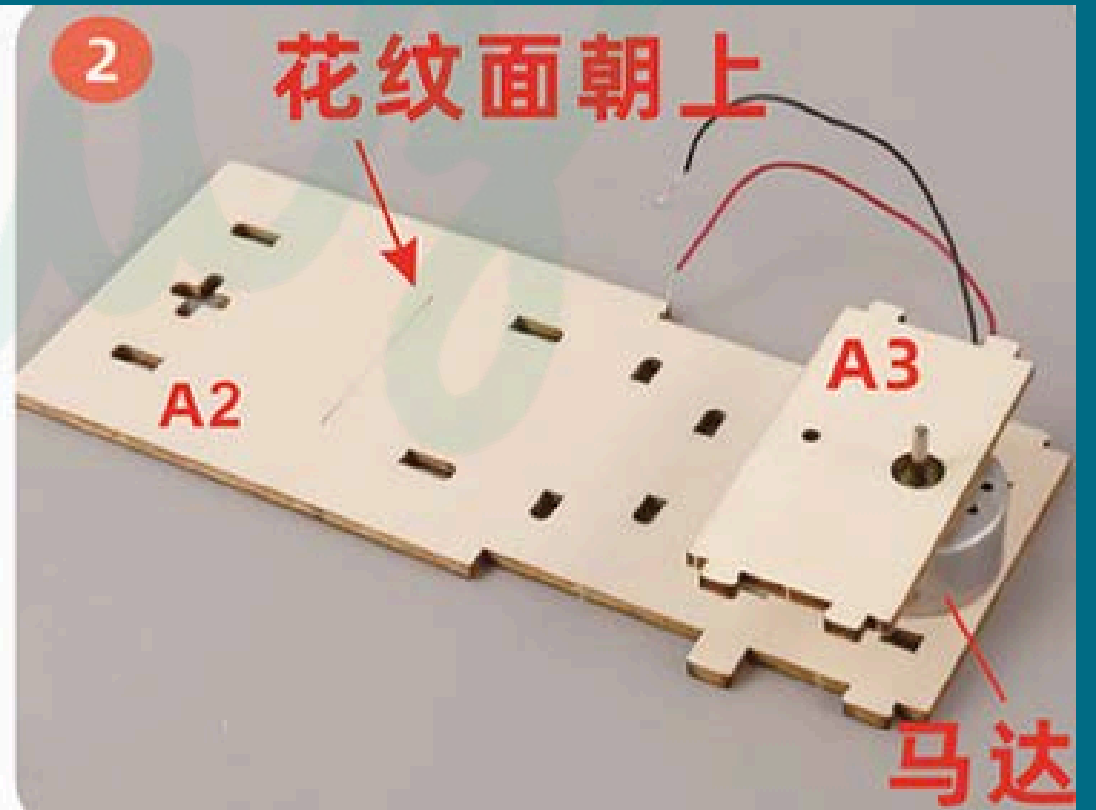
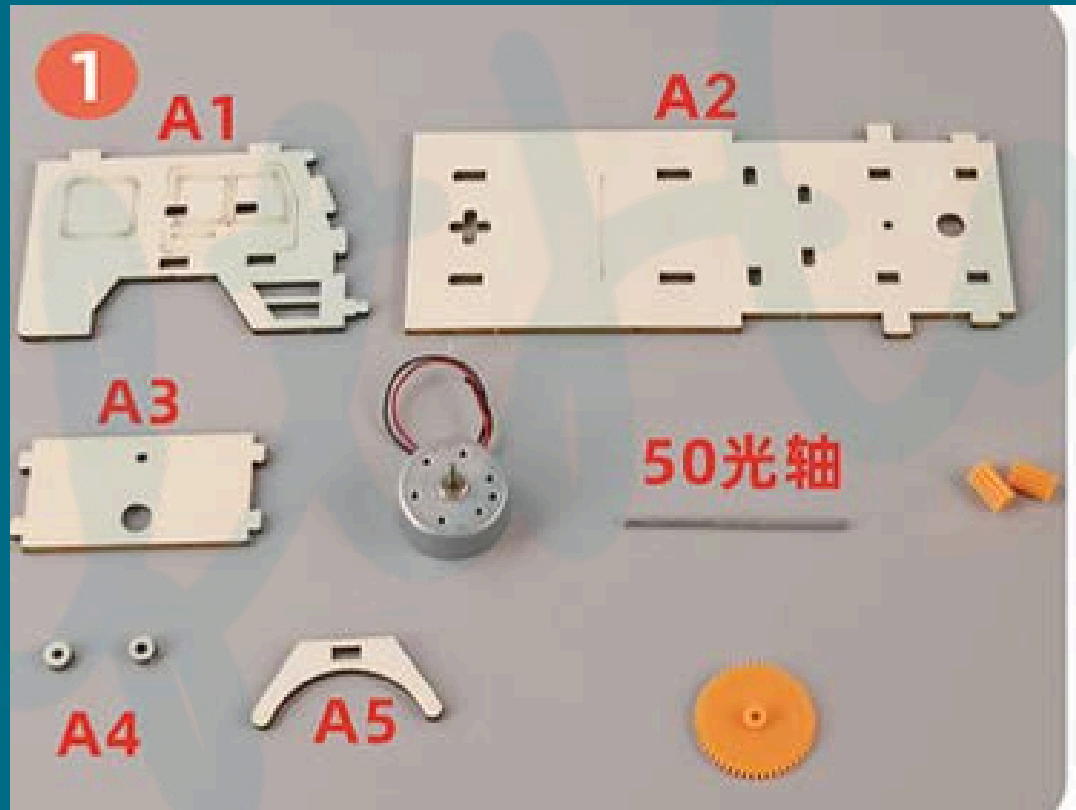

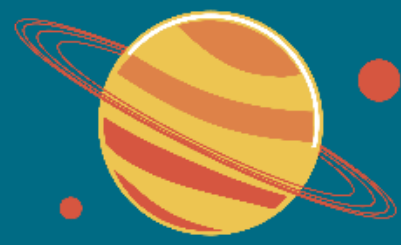

Install A1 wooden board as shown, note the textured side faces outward
Install A5 wooden board as shown

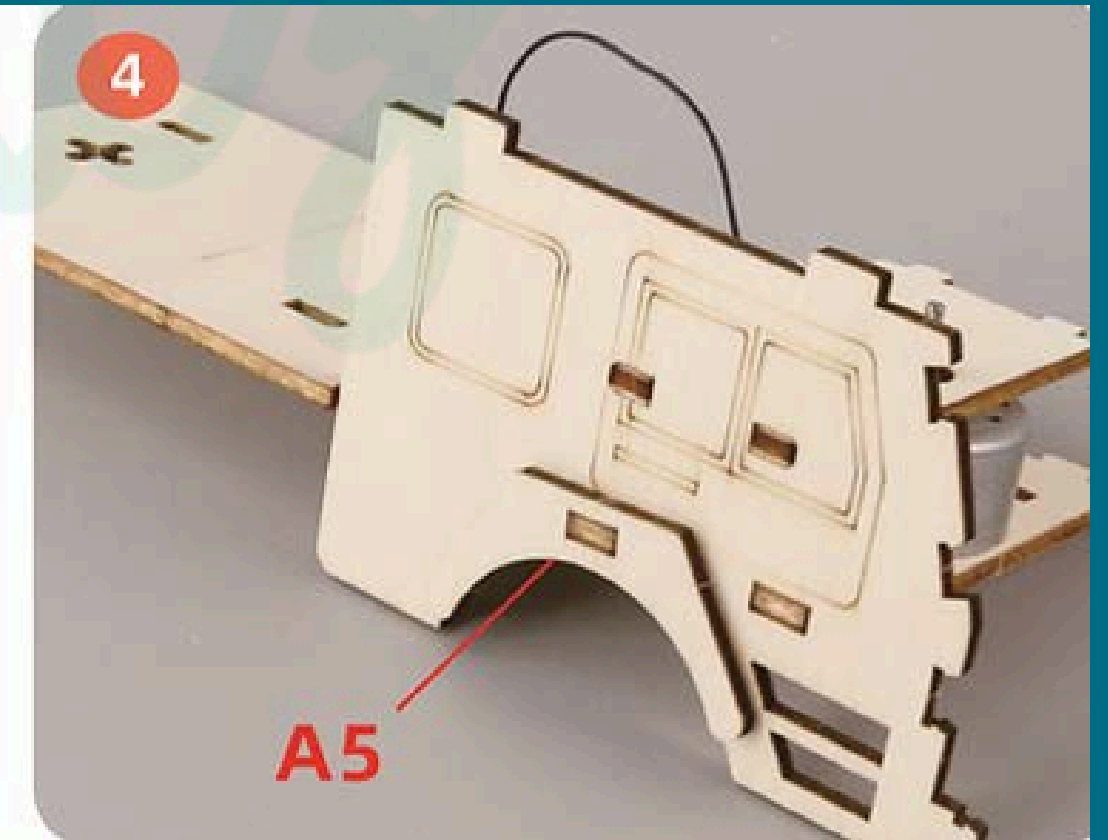
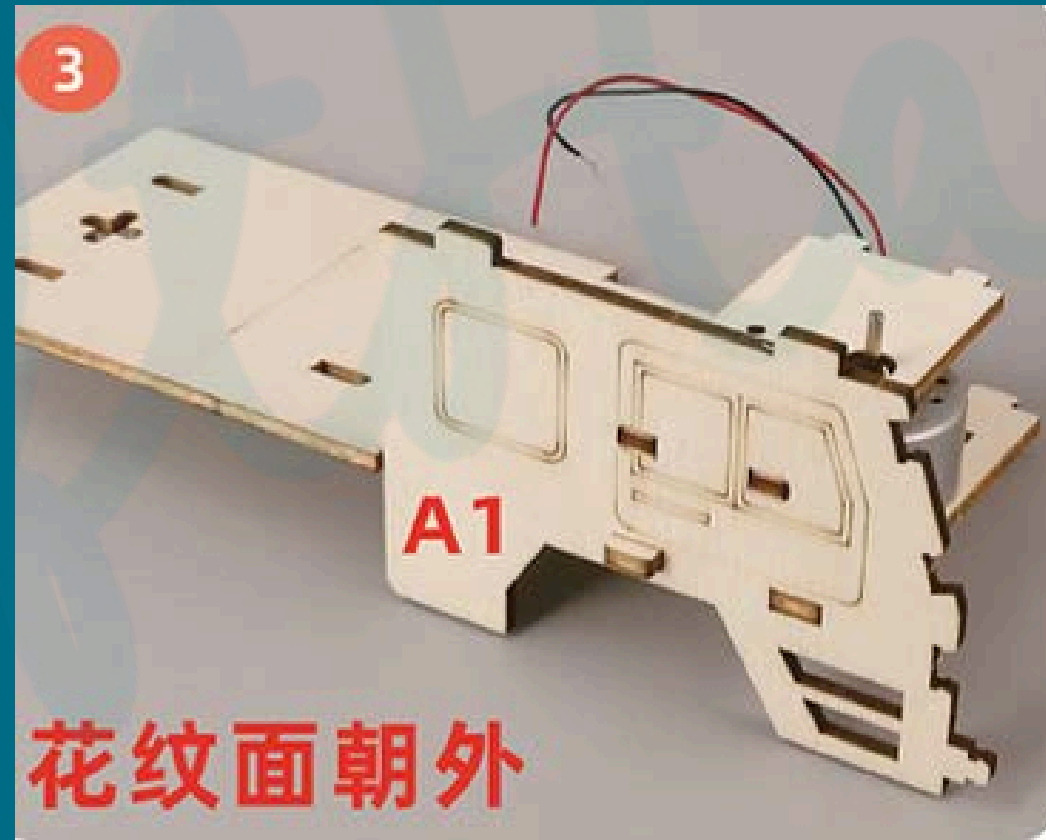

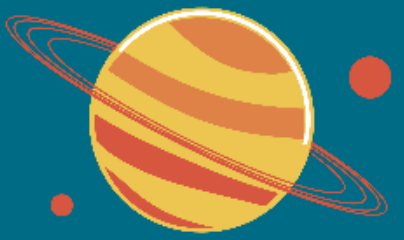

As shown, install the small long gear on the motor shaft and thread the round orange gear onto the 50mm light axle, inserting it into the wooden board's round hole

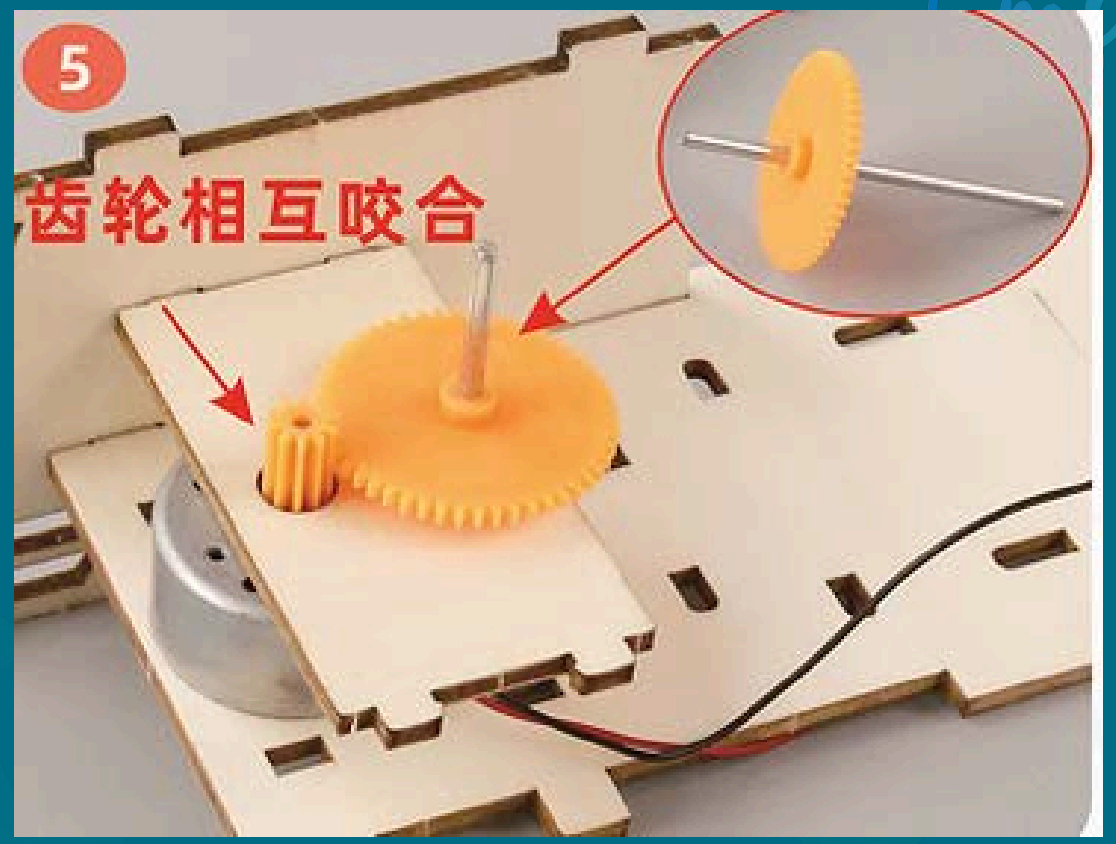

As shown, thread two A4 wooden boards onto the bottom light axle, then fit the long gear

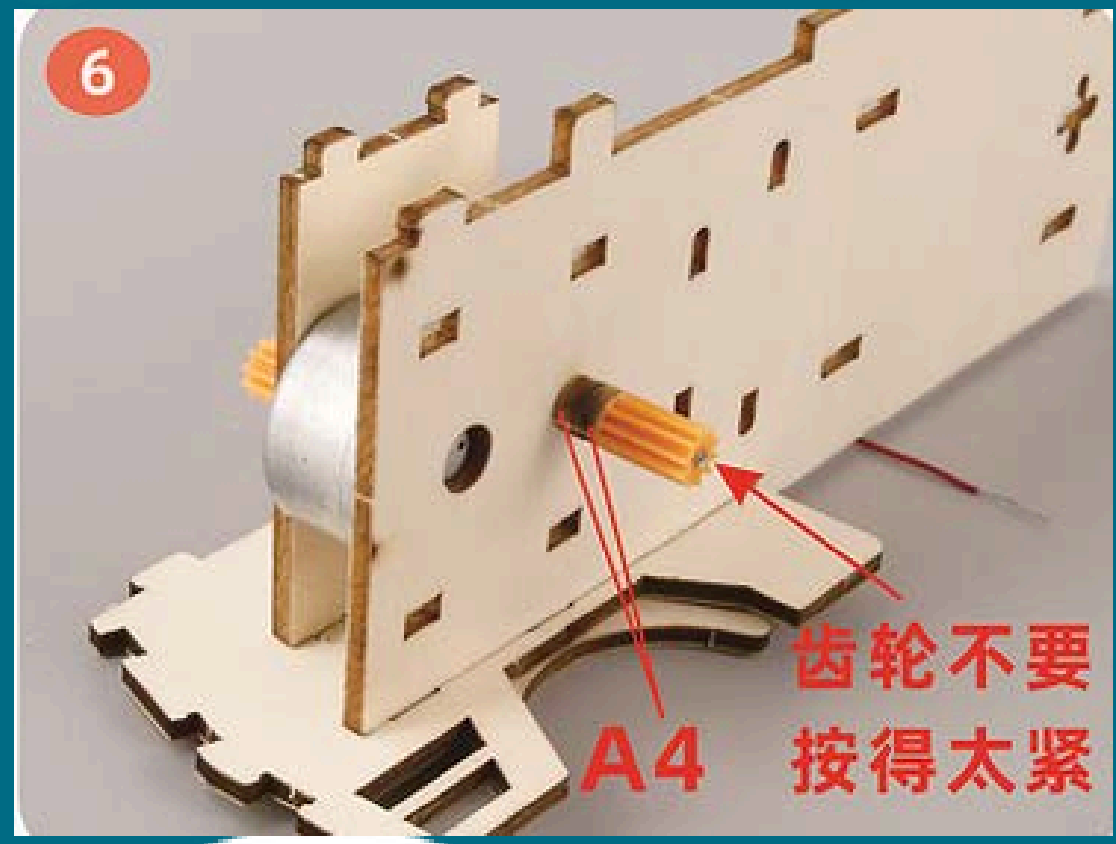

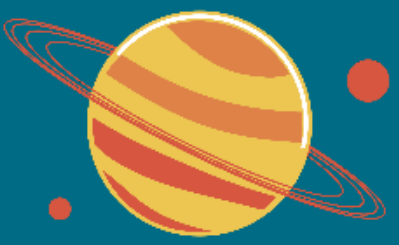

Prepare the above materials as shown
Install B1 wooden board with textured side facing outward as shown

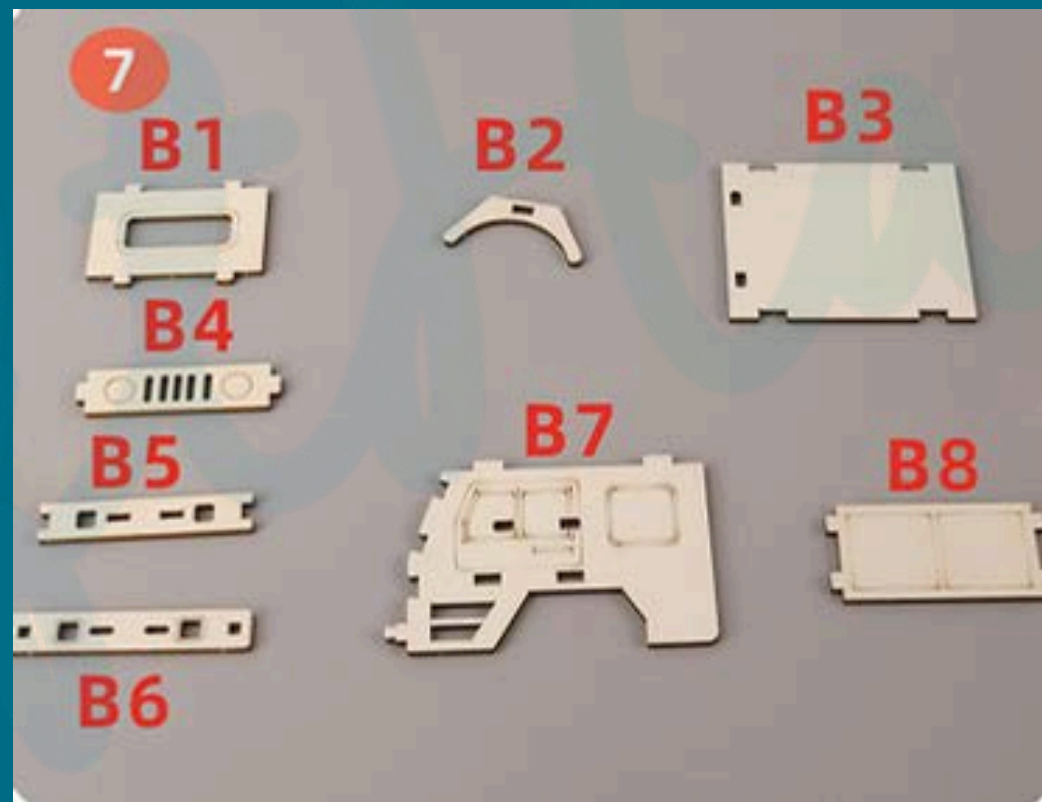

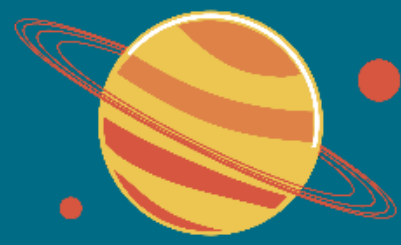

Install B2/B7 wooden boards with textured side facing outward as shown

Install B4/B5/B8 wooden boards as shown

Note: When installing B4/B5 boards, press down on both sides to snap tight, do not press the middle (easy to break)

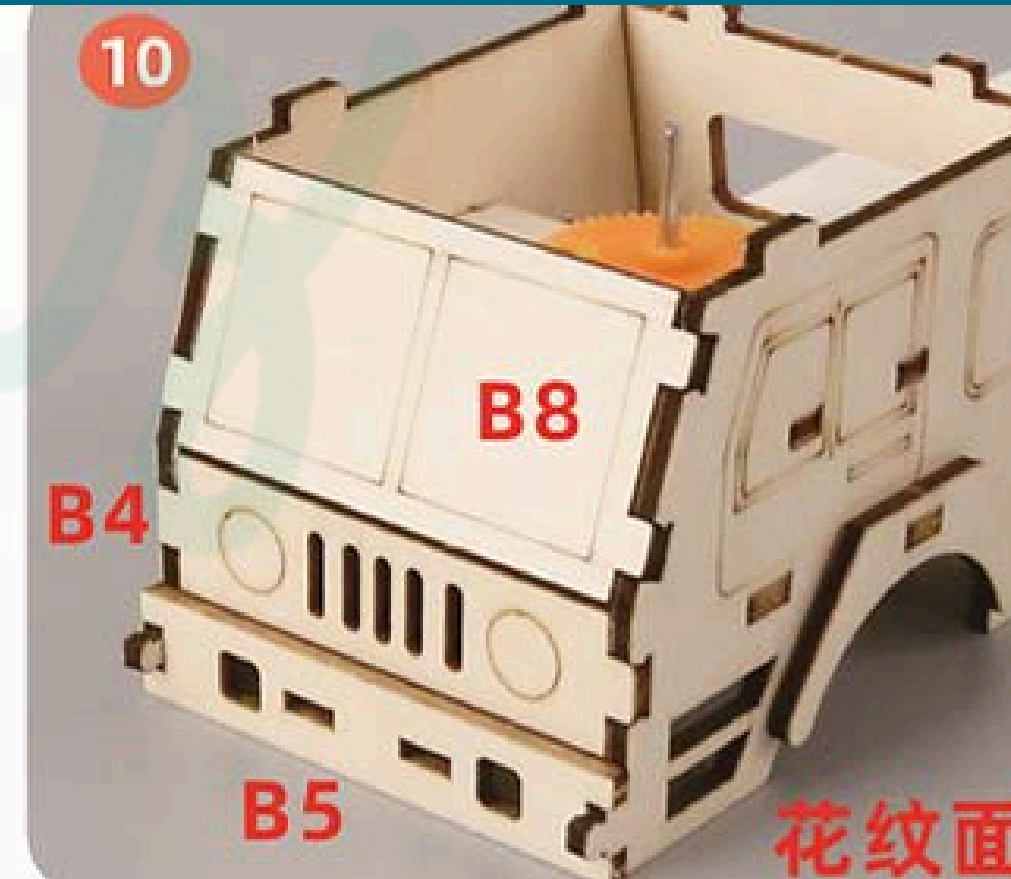
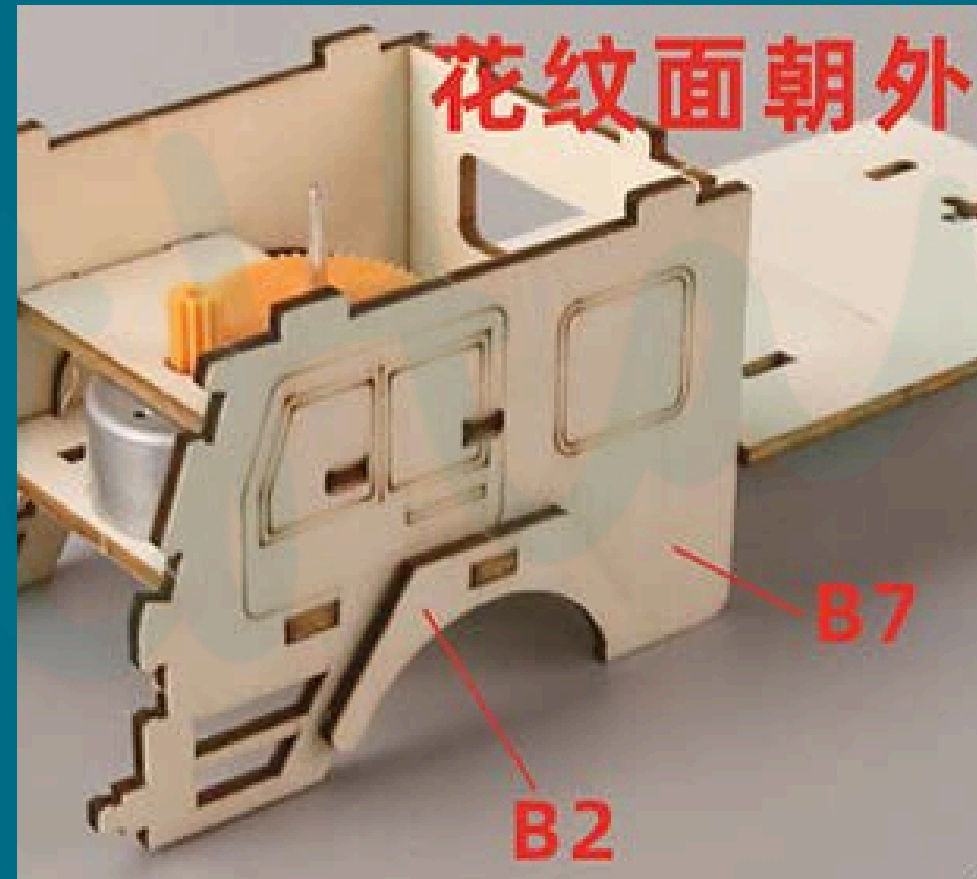

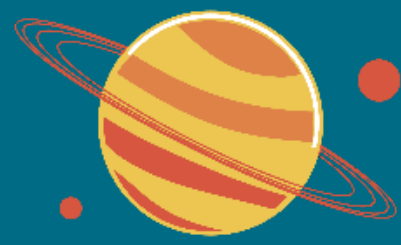

Install B6 wooden board with textured side facing outward as shown

First thread the motor wire through the B1 square hole, then install B3 wooden board as shown

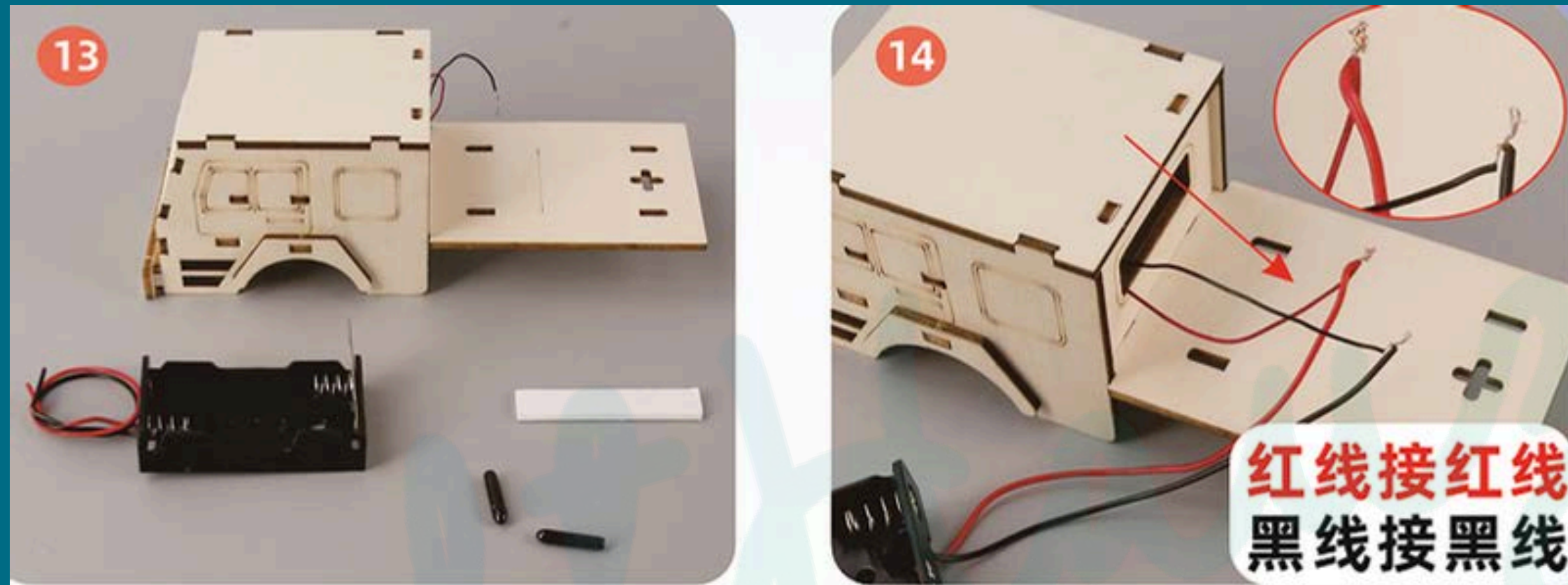
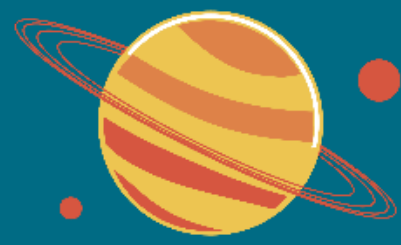

Prepare the above materials as shown
Connect the red and black wires of the battery box to
the red and black wires of the motor, twisting the
copper wires together as shown

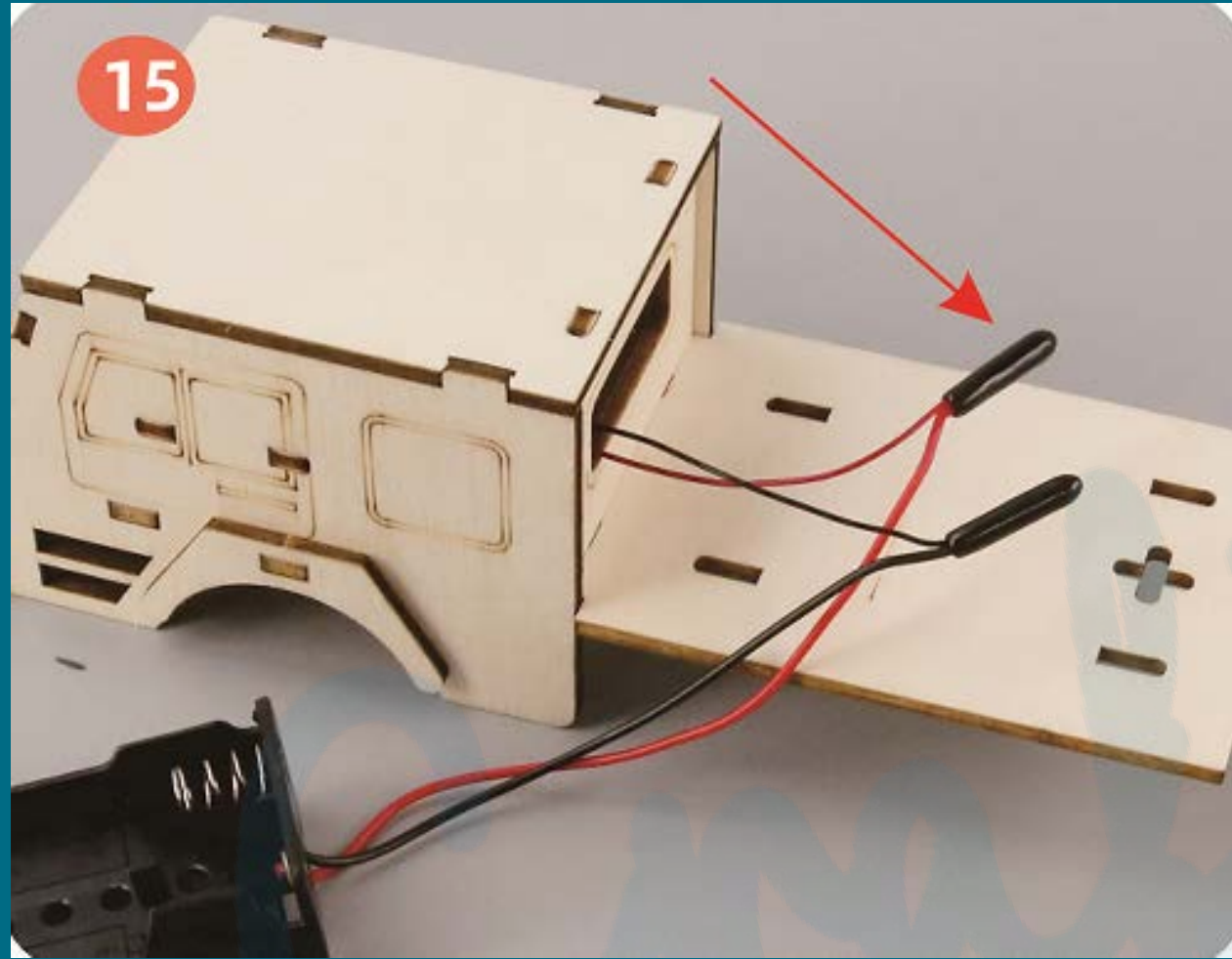
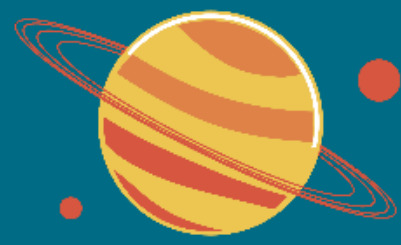

Put one insulated cap on each of the red and black wires as shown

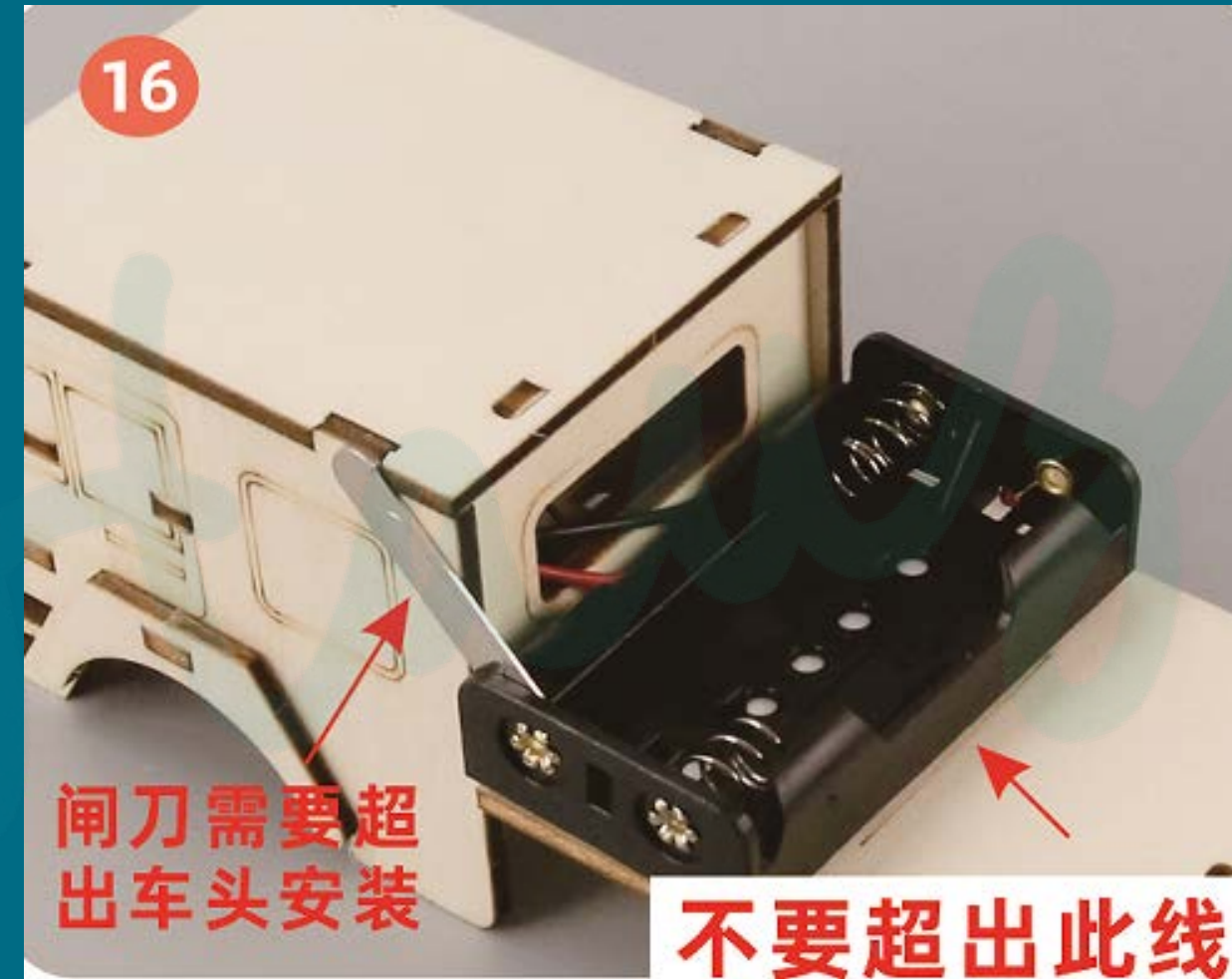

Tuck the red and black wires into the vehicle head and use foam glue to attach the battery box to the rear wooden board as shown



Prepare the above materials as shown



Install C1 wooden board at the bottom of the vehicle head and thread the crown gear onto the 50mm light axle, inserting it into the C1 wooden board's small hole to mesh with the long gear as shown

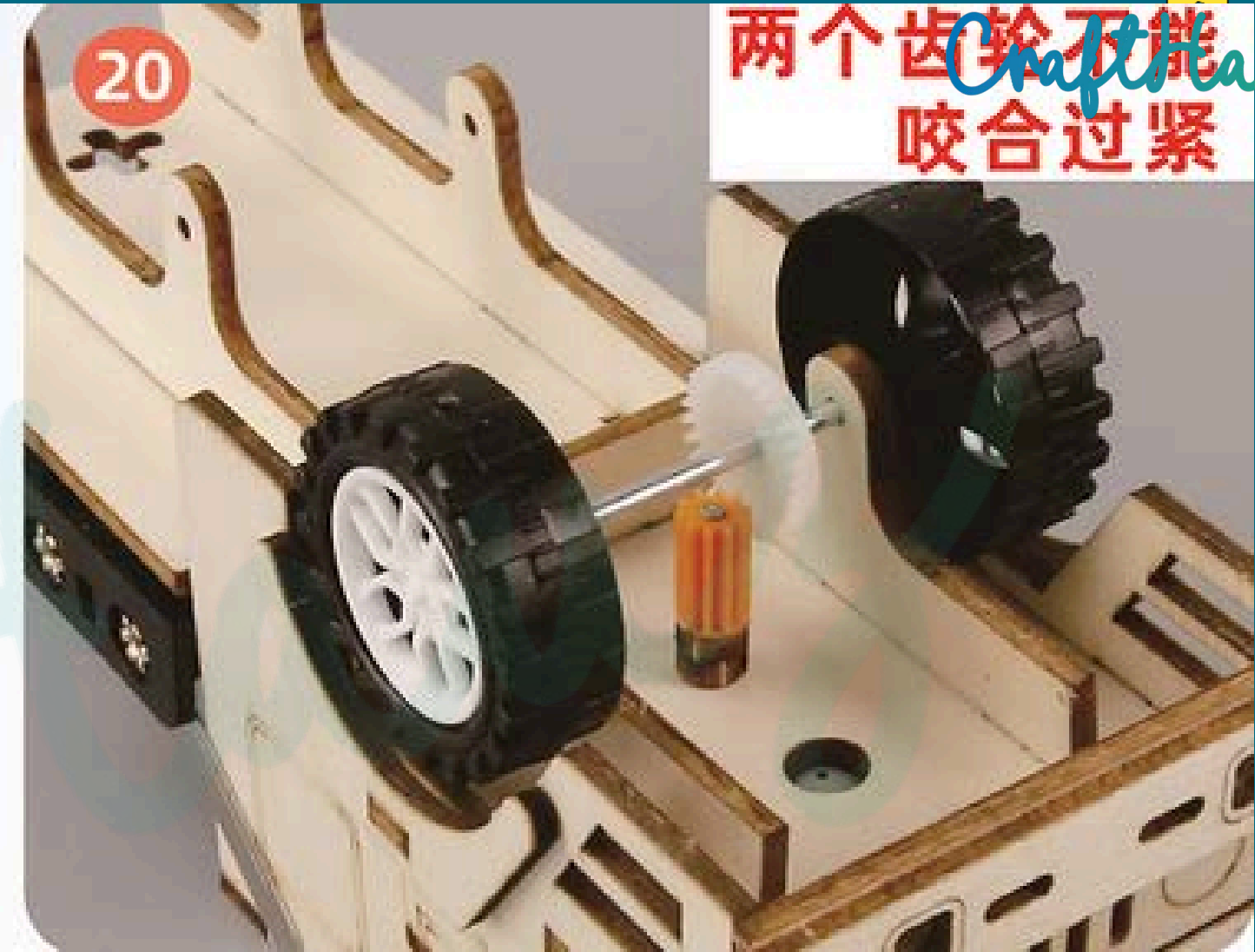
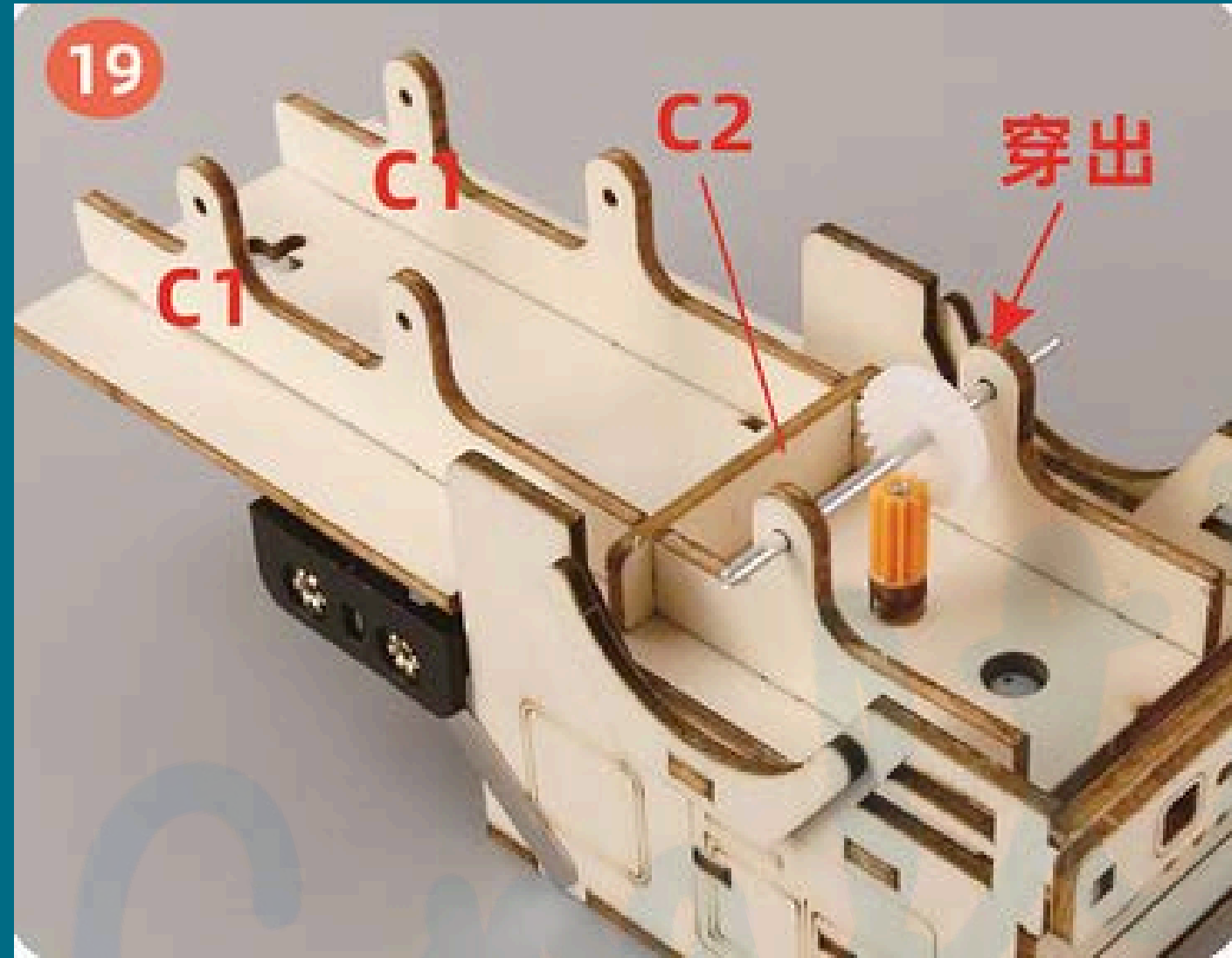
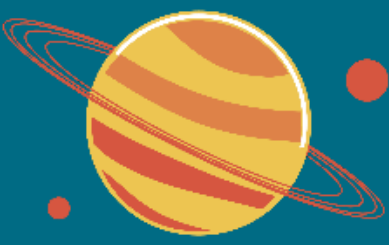

Install C1 wooden board on the other side of the vehicle head bottom and snap C2 wooden board into the groove to secure as shown

Install wheels as shown.

Note: Wheels need to be pressed tightly so the crown gear won't move left or right

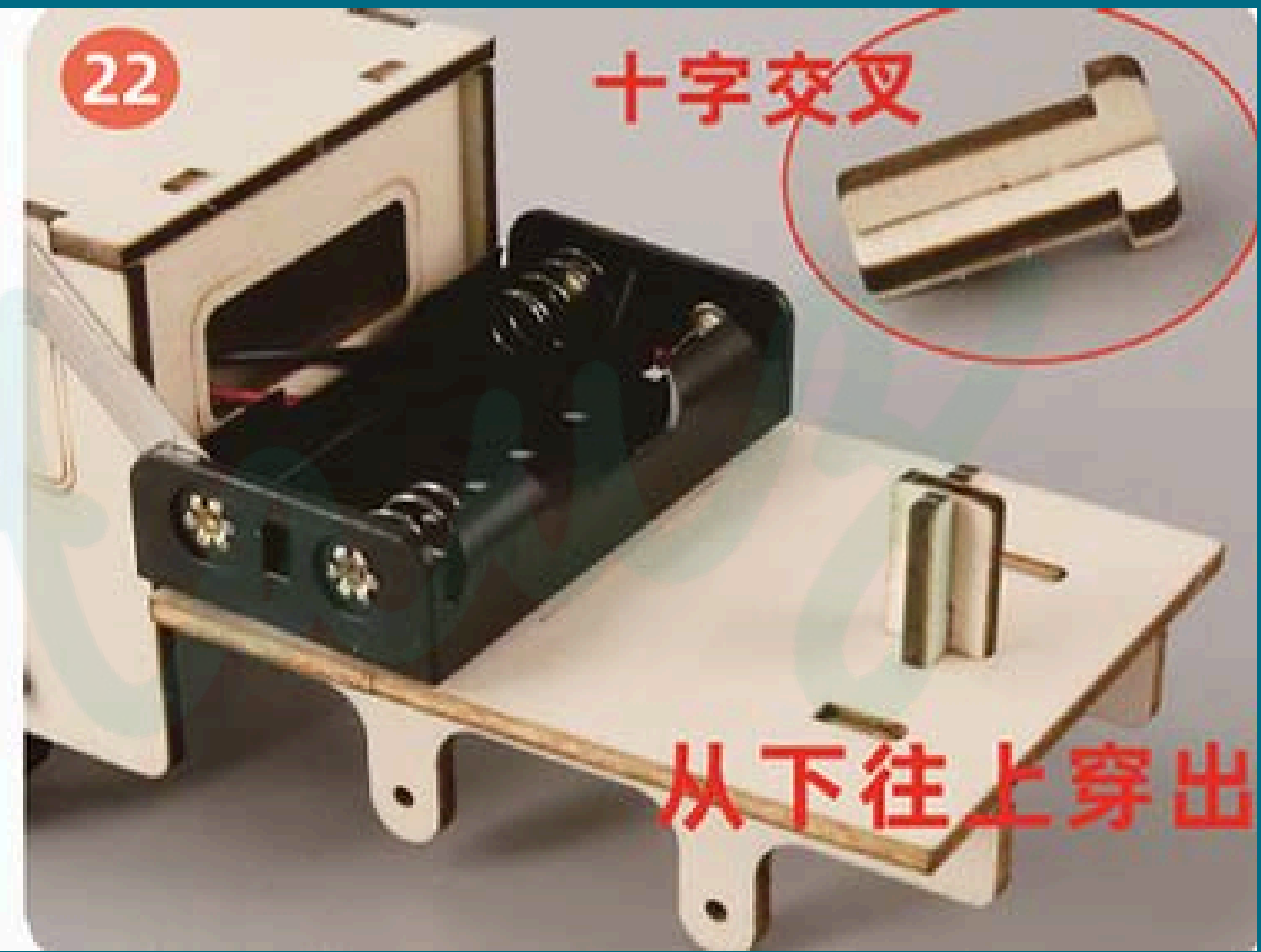
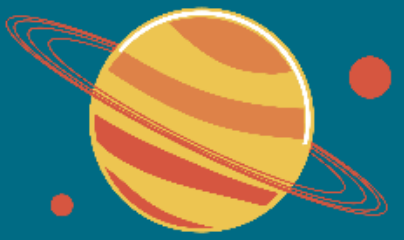

Prepare the above materials as shown
Install C3/C4 in a cross pattern from the vehicle head tail, threading from bottom to top as shown

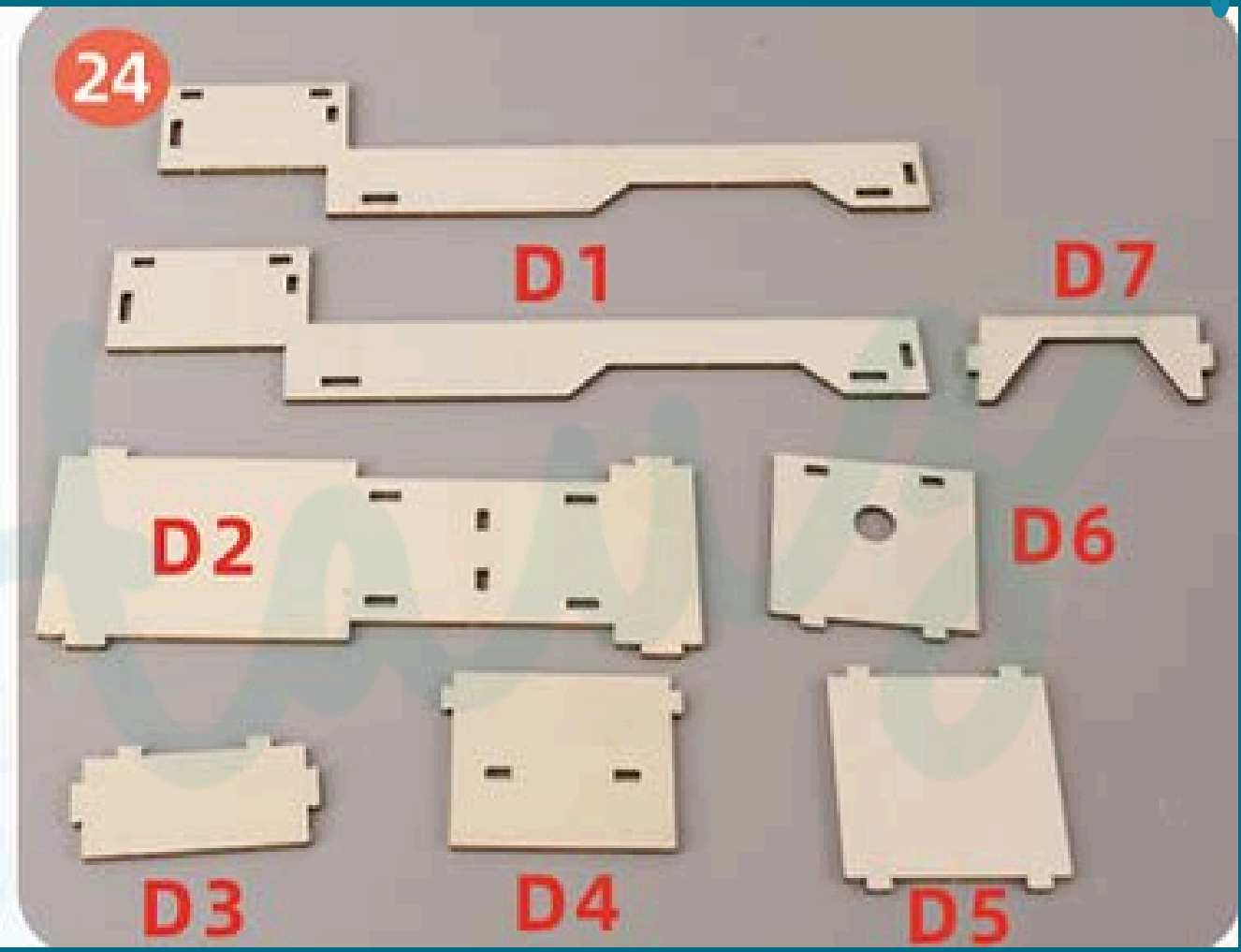
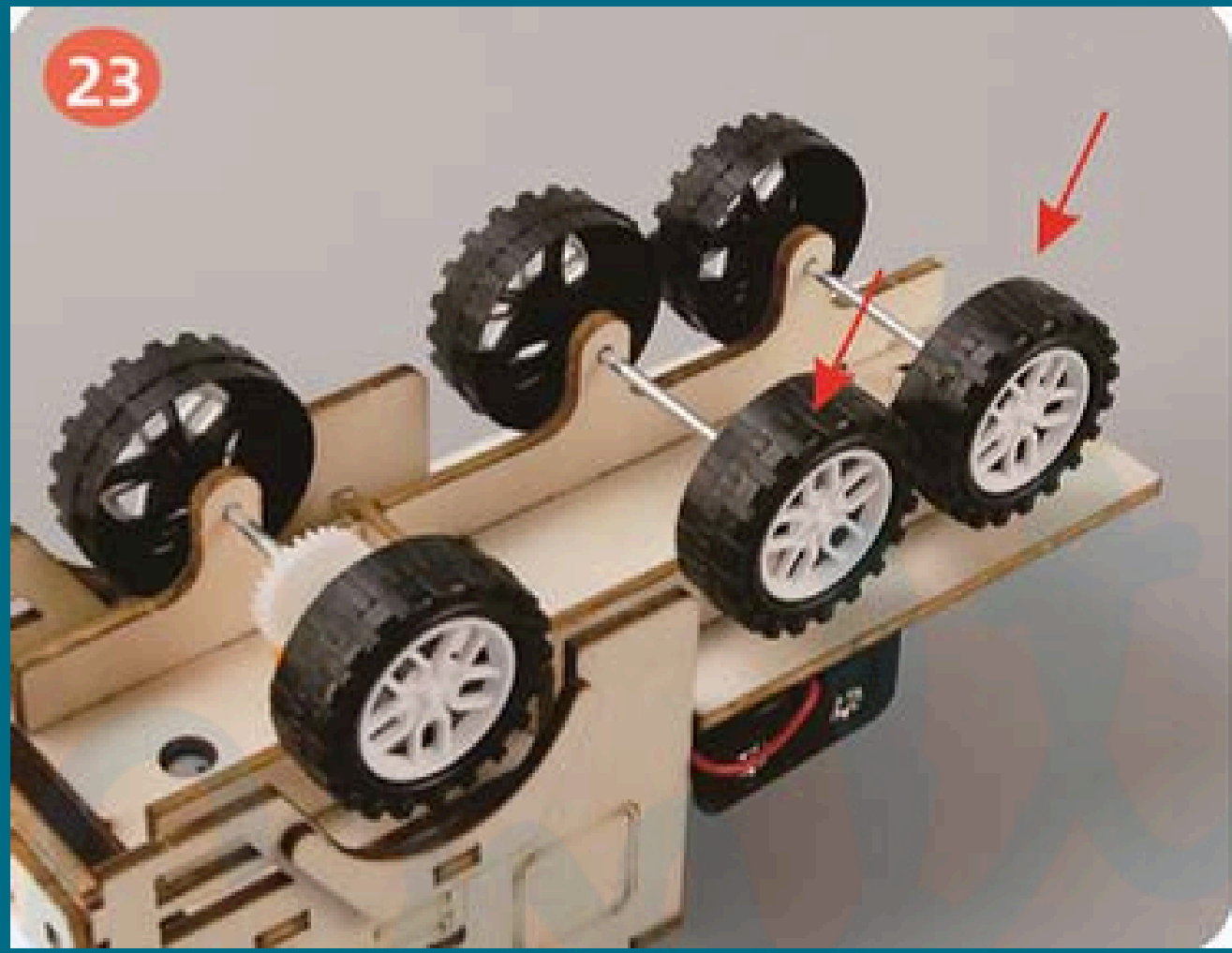
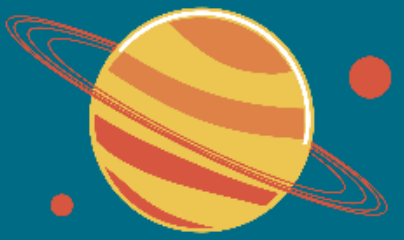

Install the rear wheels as shown
Prepare the above materials as shown



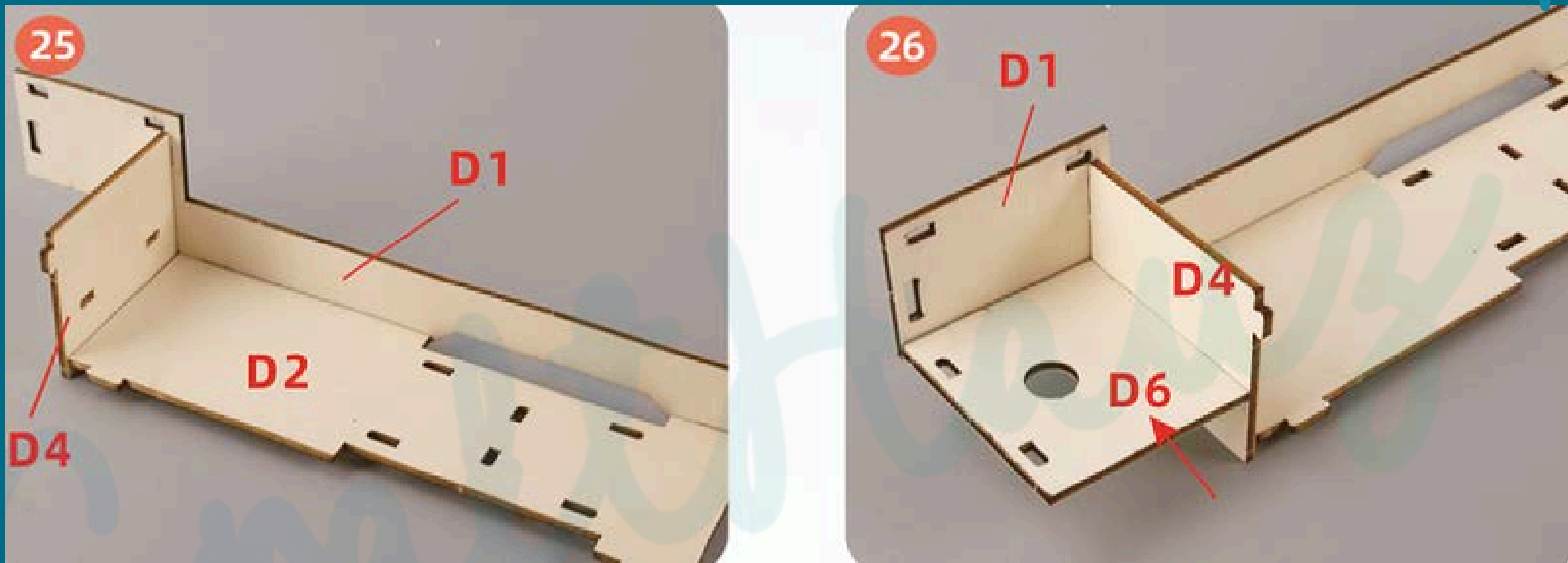

Install D1/D2/D4 wooden boards as shown

Install D6 wooden board at the front end as shown



Install D3/D5 wooden boards at the front end as shown

Install D7 wooden board at the rear side as shown

Install D1 wooden board on the other side as shown

Prepare the above materials as shown

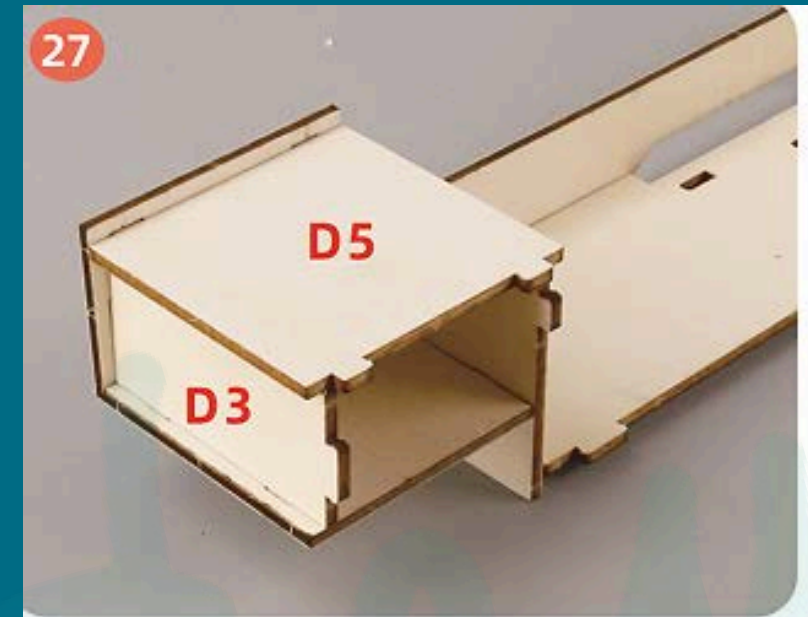

如图在前端安装D3/D5号木板

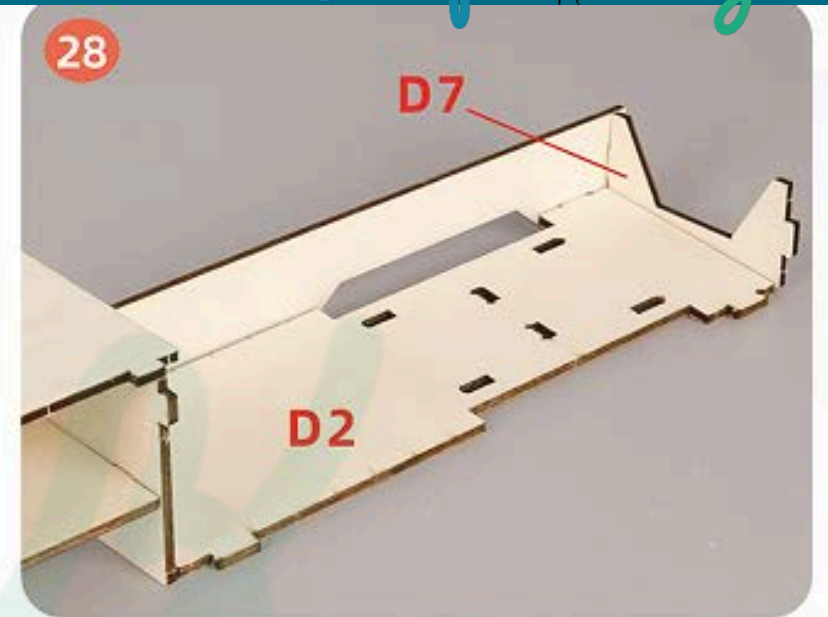

如图在后侧安装D7号木板

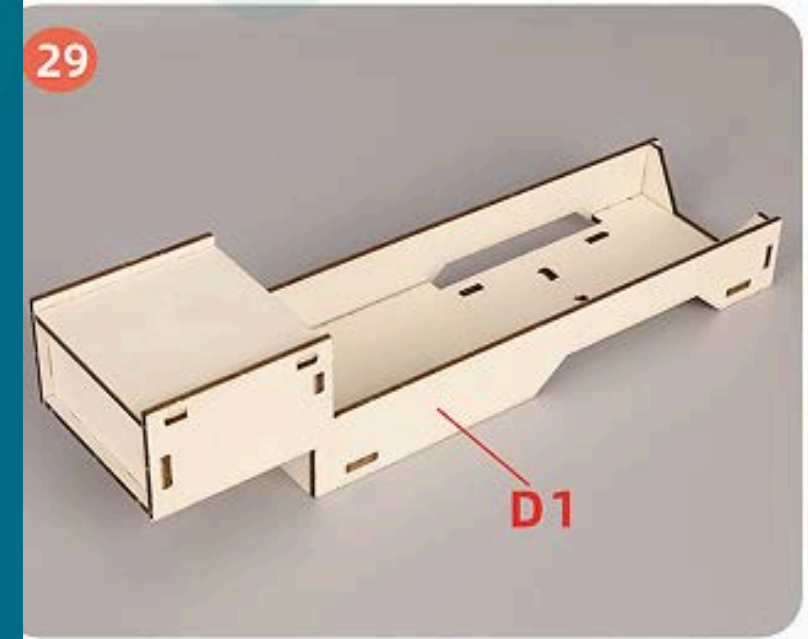

如图安装另一侧D1号木板

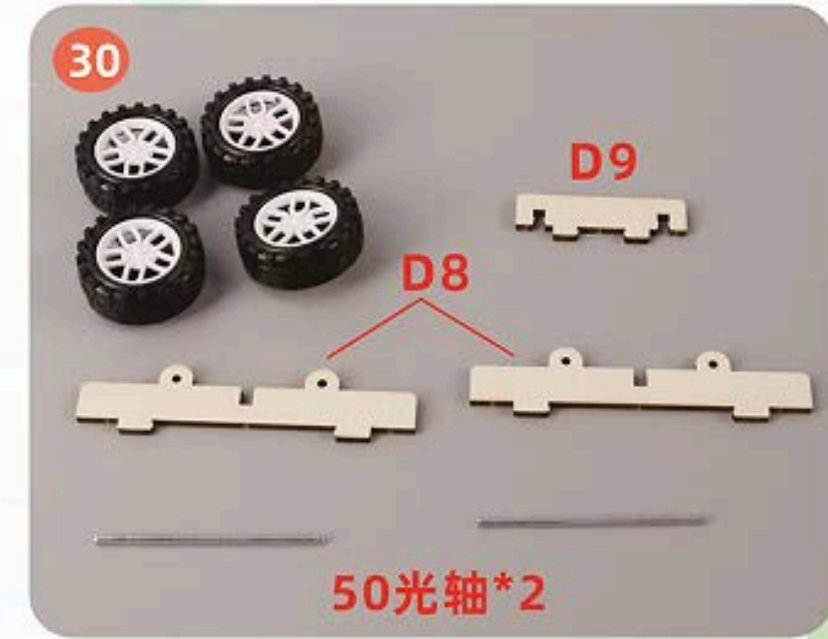

如图准备以上材料

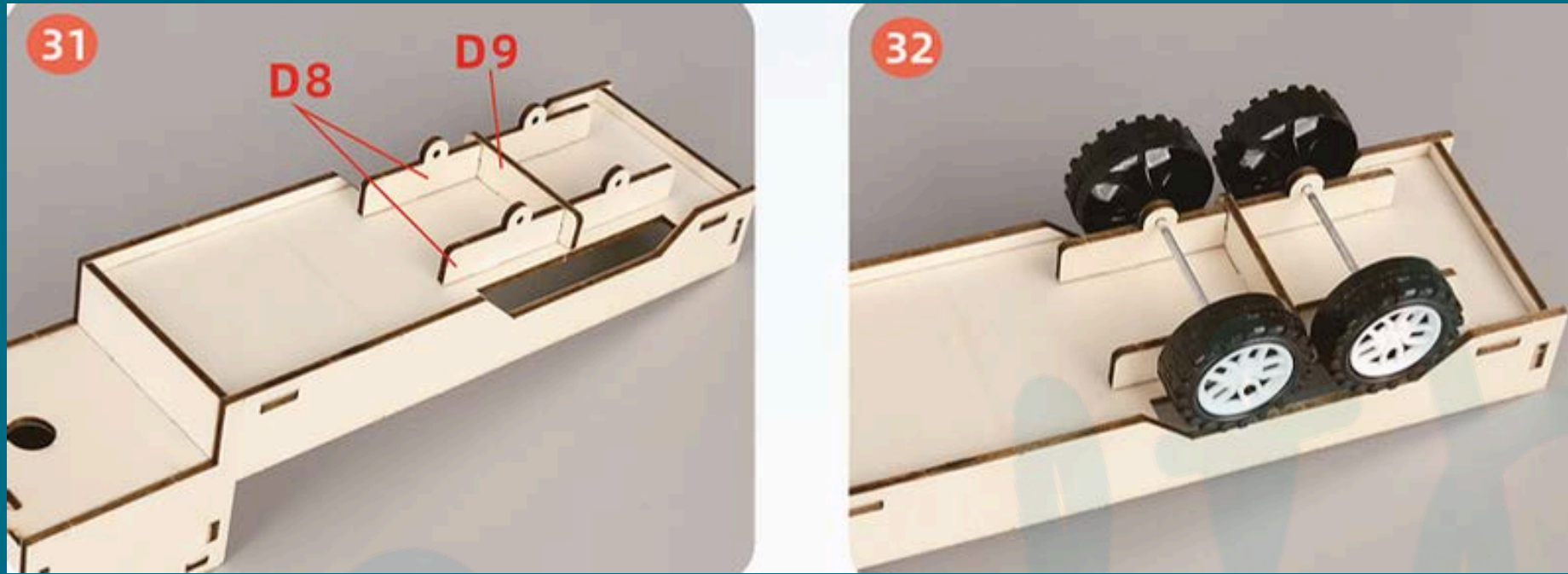

Install D8/D9 wooden boards at the bottom as shown
Install rear wheels as shown



Connect the rear cargo compartment to the vehicle head as shown



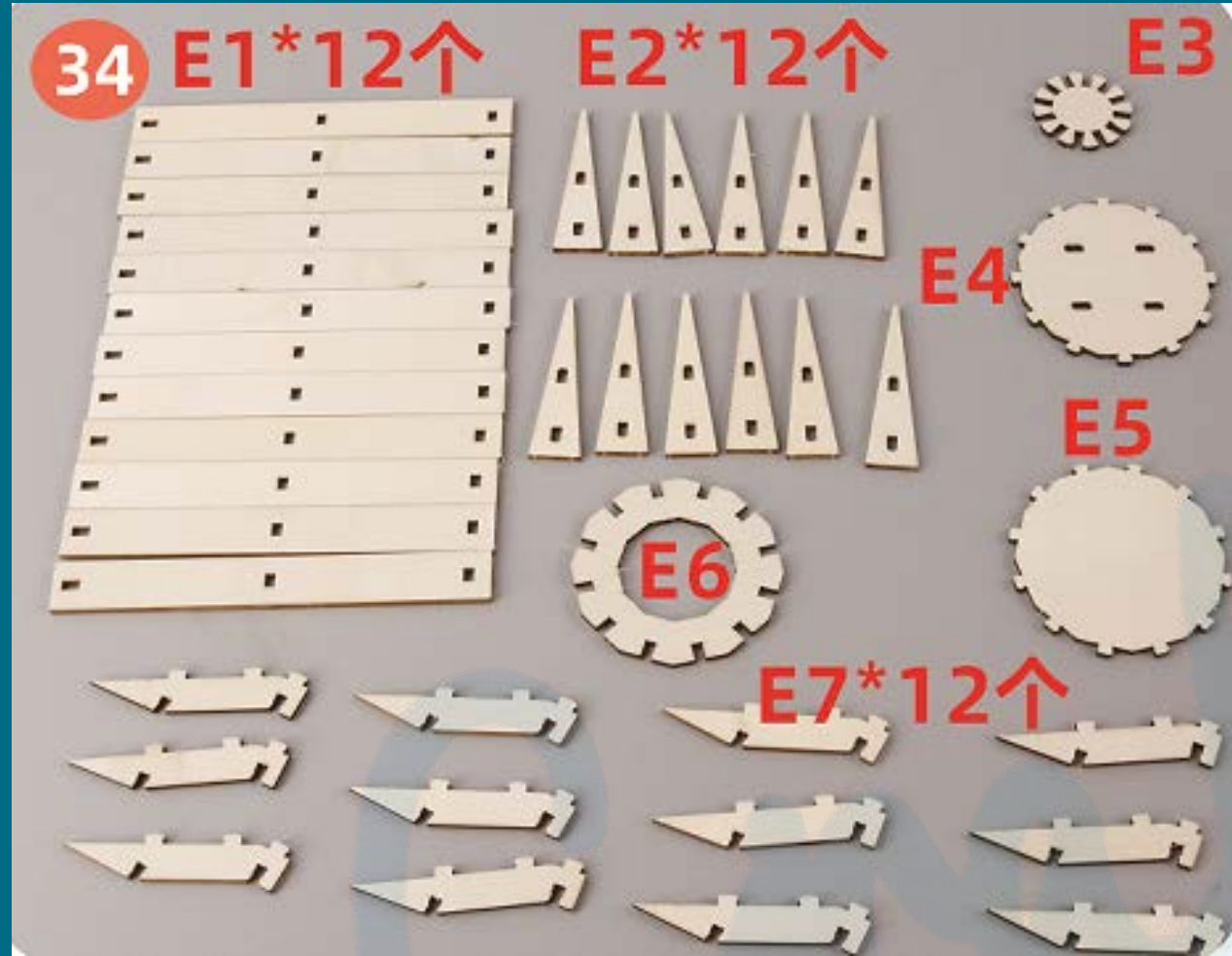

Snap D3 into the D4 wooden board groove as shown

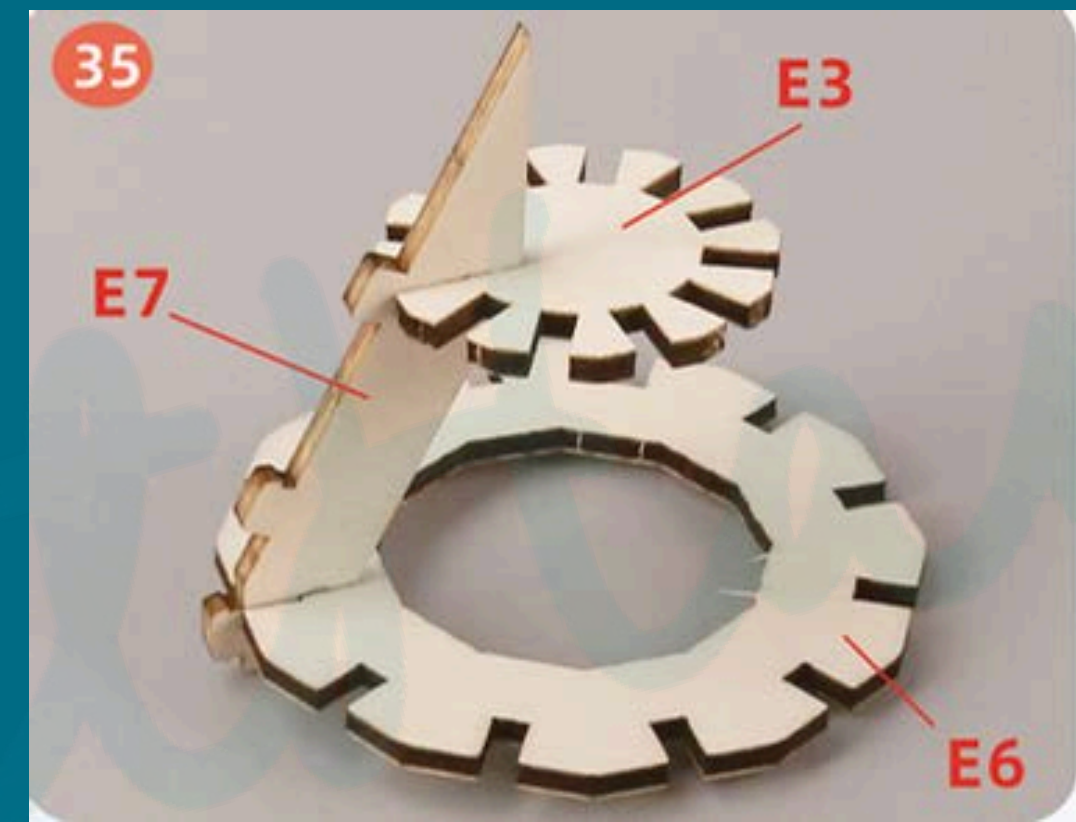

Install E3/E6/E7 wooden boards as shown

Install a circle of E7 wooden boards following the previous step method as shown

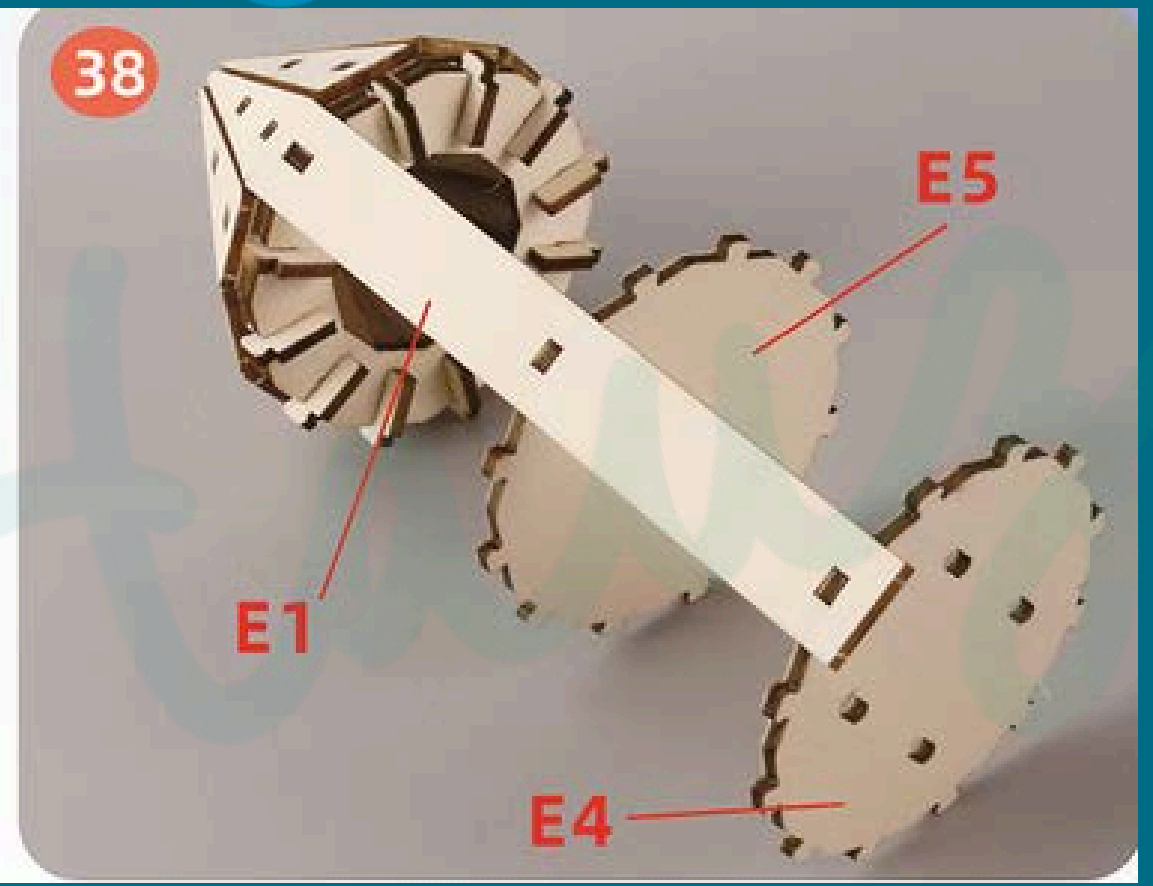

Install E2 wooden boards in a circle as shown

Install E1/E4/E5 wooden boards as shown



Install E1/E4/E5 wooden boards in a circle and prepare the next step boards (lower left corner) as shown

Install boards in a cross pattern as shown



Install the above assembly at the bottom of the missile as shown

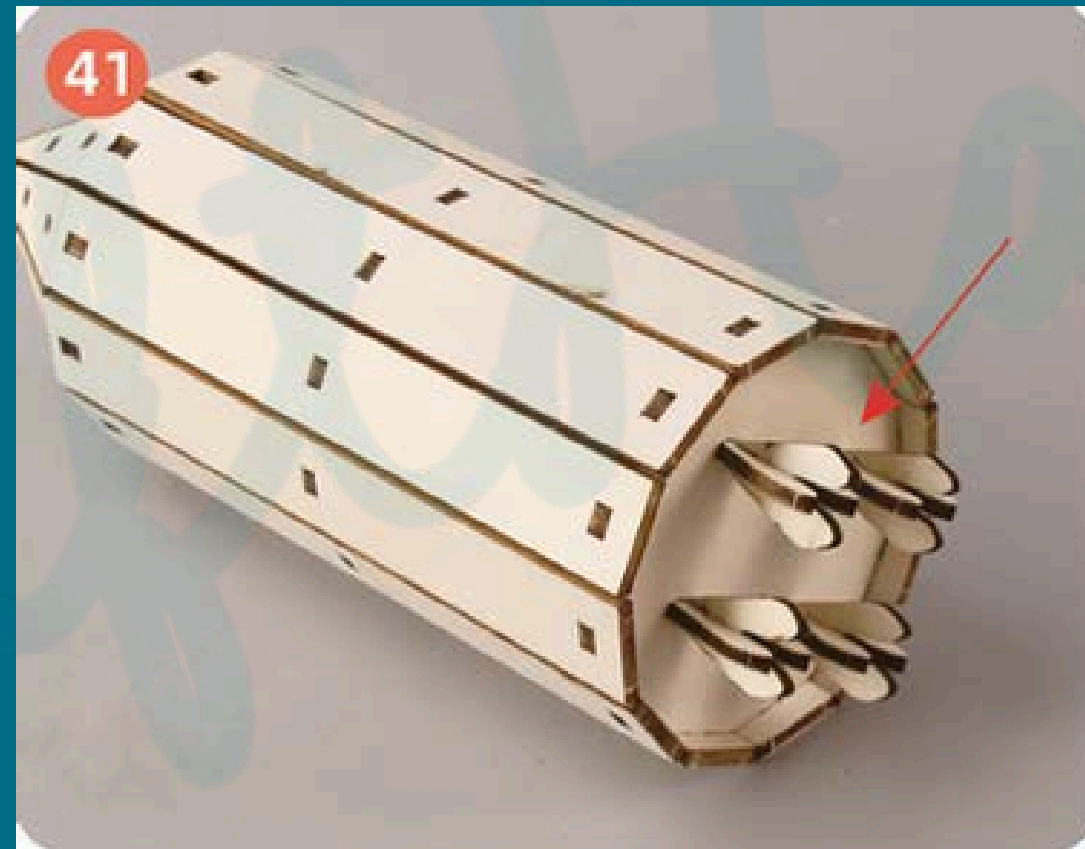



Principle

CraftHausz



This missile vehicle uses a DC motor to convert electrical energy into mechanical energy, then achieves speed reduction and torque increase through a "small-to-large" gear set, smoothly transmitting power to the wheels to drive the model forward. At the same time, the modular wooden structure recreates the vehicle body and wheeled chassis design of the missile launch vehicle, visually demonstrating the core logic of "power-transmission-execution" in mechanical engineering, helping us understand the mechanical principles of motor drive and gear transmission, as well as the structural stability and power transmission characteristics of engineering equipment.

